

Proportional relief valves

direct operated, ISO 4401 size 06 subplate mounting or M20 screw-in cartridge execution

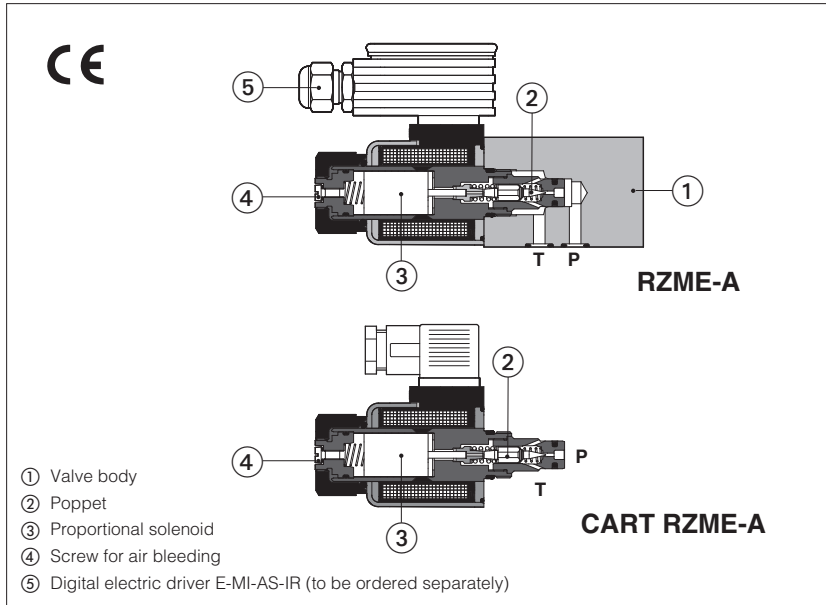

RZME-A, CART RZME-A

Open loop, poppet type direct operated proportional pressure relief valves with proportional solenoids certified according to North American standard **cURus**.

They operate in association with electronic drivers, see section 2, which supply the proportional valves with proper current to align the valve regulation to the reference signal.

They are available in following executions:

RZME: subplate mounting, ISO size 06

CART RZME: M20 cartridge execution

The solenoid coils are plastic encapsulated with insulation class H and they are available with different nominal resistances depending to the voltage supply (12 Vdc or 24 Vdc) and to the electronic driver type, see section 2 and 3.

Mounting surface RZME: **ISO 4401 size 06**

Cavity CART RZME: see section 4

Max flow = **4 l/min**

Max pressure = **350 bar**

1 MODEL CODE

RZME	-	A	-	010	/	315	-	*	/	*	**	/	*
<p>Proportional pressure relief valve RZME = subplate mounting CART RZME = cartridge execution</p> <p>A = open loop pressure control</p> <p>Configuration: 010 = regulation on port P, discharge in T</p> <p>Max regulated pressure: 50 = 50 bar 100 = 100 bar 210 = 210 bar 315 = 315 bar 350 = 350 bar</p> <p>Coil voltage see section 2 and 3: - = standard coil for 24V_{dc} Atos drivers 6 = optional coil for 12V_{dc} Atos drivers 18 = optional coil for low current drivers (1)</p> <p>Coils with special connectors, see section 9 - = omit for standard DIN connector J = AMP Junior Timer connector K = Deutsch connector S = Lead Wire connection</p> <p>Seals material, see section 4: - = NBR PE = FKM BT = HNBR</p> <p>Series number</p>													

(1) select valve's coil voltage /18 in case of electronic drivers not supplied by Atos, with power supply 24V_{dc} and with max current limited to 1A.

2 ELECTRONIC DRIVERS

Drivers model	E-MI-AC (1)		E-MI-AS-IR (1)		E-BM-AC		E-BM-AS-PS		E-BM-AES		E-ME-AC
Type	analog		digital		analog		digital		digital		analog
Voltage supply (V _{dc})	12	24	12	24	12	24	12	24	24		24
Valve coil option	/6	std	/6	std	/6	std	/6	std	std		std
Format	DIN 43650 plug-in to solenoid				DIN 43700 UNDECAL		DIN-rail panel				EUROCARD
Data sheet	G010		G020		G025		G030		GS050		G035

(1) for **CART RZME** the electronic driver may interfere with the manifold surface. Please check the installation dimensions at section 10

3 HYDRAULIC CHARACTERISTICS (based on mineral oil ISO VG 46 at 50 °C)

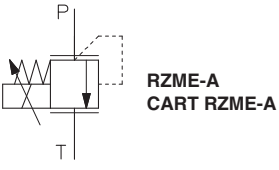
Hydraulic symbols			
Assembly position / location	Any position		
Subplate surface finishing (RZME)	Roughness index Ra 0,4 - flatness ratio 0,01/100 (ISO 1101)		
Ambient temperature	Standard = -20°C ÷ +70°C; /PE option = -20°C ÷ +70°C; /BT option = -40°C ÷ +70°C		
Coil code	Standard standard coil to be used with Atos drivers with power supply 24Vdc	option /6 optional coil to be used with Atos drivers with power supply 12 Vdc	option /18 optional coil to be used with electronic drivers not supplied by Atos, with power supply 24 Vdc and max current limited to 1A
Coil resistance R at 20°C	3 ÷ 3,3 Ω	2 ÷ 2,2 Ω	13 ÷ 13,4 Ω
Max. solenoid current	2,2 A	2,75 A	1 A
Max. power	30 Watt		
Protection degree (CEI EN-60529)	IP65		
Duty factor	Continuous rating (ED=100%)		
Certification	cURus North American Standard		

Max regulated pressure [bar]	50	100	210	315	350
Min. regulated pressure [bar]	see min. pressure / flow diagrams at sect. 7				
Max. pressure at port P [bar]	350				
Max. pressure at port T [bar]	210				
Max. flow [l/min]	4				
Response time 0-100% step signal (1) (depending on installation) [ms]	≤ 70				
Hysteresis [% of the max pressure]	≤ 1,5				
Linearity [% of the max pressure]	≤ 3				
Repeatability [% of the max pressure]	≤ 2				

Notes: above performance data refer to valves coupled with Atos electronic drivers, see section 2.

(1) Average response time values; the pressure variation in consequence of a modification of the reference input signal to the valve is affected by the stiffness of the hydraulic circuit: greater is the stiffness of the circuit, faster is the dynamic response.

4 SEALS AND HYDRAULIC FLUID

Seals, recommended fluid temperature	NBR seals (standard) = -20°C ÷ +60°C, with HFC hydraulic fluids = -20°C ÷ +50°C FKM seals (/PE option) = -20°C ÷ +80°C HNBR seals (/BT option) = -40°C ÷ +60°C, with HFC hydraulic fluids = -40°C ÷ +50°C		
Recommended viscosity	20 ÷ 100 mm ² /s - max allowed range 15 ÷ 380 mm ² /s		
Fluid contamination class	ISO 4406 class 20/18/15 NAS 1638 class 9, in line filters of 10 μm (β10 ≥75 recommended)		
Hydraulic fluid	Suitable seals type	Classification	Ref. Standard
Mineral oils	NBR, FKM, HNBR	HL, HLP, HLPD, HVLP, HVLDP	DIN 51524
Flame resistant without water	FKM	HFDU, HFDR	ISO 12922
Flame resistant with water	NBR, HNBR	HFC	

Note: For other fluids not included in above table, consult our technical office

5 GENERAL NOTES

RZME-A and CART RZME proportional valves are CE marked according to the applicable Directives (e.g. Immunity/Emission EMC Directive and Low Voltage Directive).

Installation, wirings and start-up procedures must be performed according to the general prescriptions shown in table F003 and in the installation notes supplied with relevant components.

6 SOLENOID CONNECTIONS

SOLENOID POWER SUPPLY CONNECTOR	
PIN	Signal description
1	SUPPLY
2	SUPPLY
3	GND

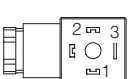

7 DIAGRAMS (based on mineral oil ISO VG 46 at 50 °C)

1 Regulation diagrams
with flow rate Q = 1 l/min

Note: The presence of counter pressure at port T can affect the effective pressure regulation.

2 Pressure/flow diagrams
with reference signal set at Q = 1 l/min

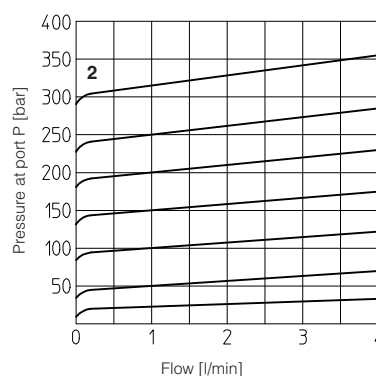
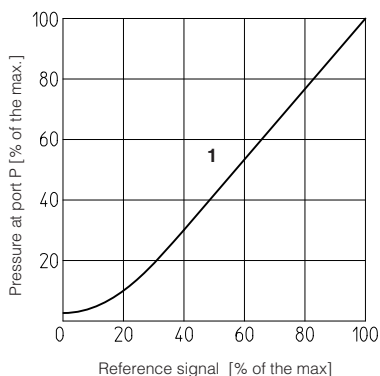

3-7 Min. pressure/flow diagrams
with zero reference signal

- 3 = pressure range: 50
- 4 = pressure range: 100
- 5 = pressure range: 210
- 6 = pressure range: 315
- 7 = pressure range: 350

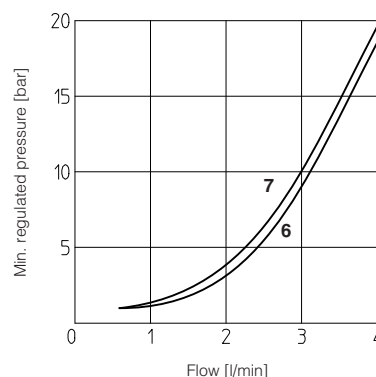
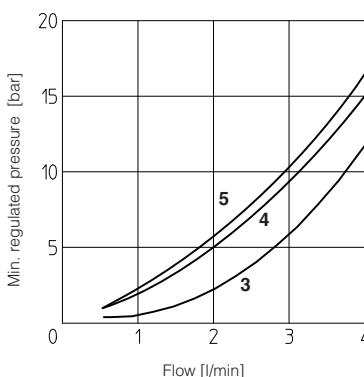

8 AIR BLEEDING

At the first valve commissioning the air eventually trapped inside the solenoid must be bled-off through the screw ① located at the rear side of the solenoid housing.
The presence of air may cause pressure instability and vibrations.

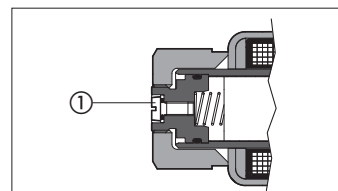

9 COILS TYPE WITH SPECIAL CONNECTORS

Options -J
Coil type COZEJ
AMP Junior Timer connector
Protection degree IP67

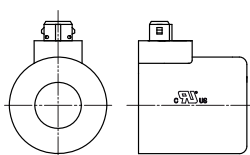

Options -K
Coil type COZEK
Deutsch connector, DT-04-2P male
Protection degree IP67

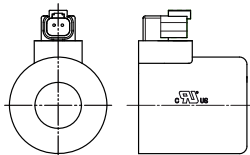

Options -S
Coil type COZES
Lead Wire connection
Cable length = 180 mm

