

Proportional relief valves

pilot operated, open loop

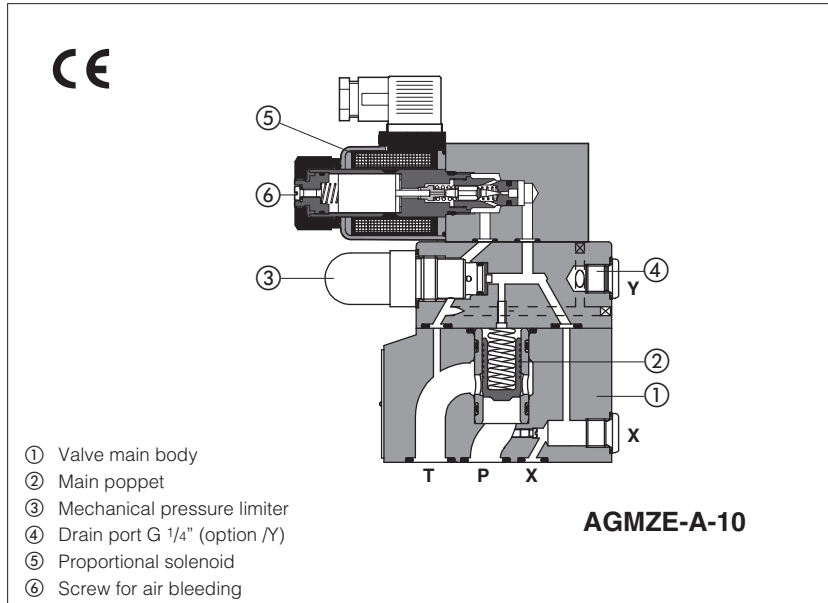

AGMZE-A

Open loop, poppet type pilot operated proportional pressure relief valves with proportional solenoids certified according to North American standard **cURus**. They operate in association with electronic drivers, see section 2, which supply the proportional valves with proper current to align the valve regulation to the reference signal.

The solenoid coils are plastic encapsulated with insulation class H and they are available with different nominal resistances depending to the voltage supply (12 VDC or 24 VDC) and to the electronic driver type, see section 2 and 3.

Size: **10, 20, 32**
Max flow: **200, 400, 600 l/min**
Max pressure: **350 bar**

1 MODEL CODE

AGMZE	-	A	-	10	/	315	/	*	-	*	/	*	/	**	/	*	
Proportional pressure relief valve pilot operated																	Seals material, see section 4: - = NBR PE = FKM BT = HNBR
		A = open loop pressure control															Series number
Valve size ISO 6264 10, 20, 32																	
Max regulated pressure: 50 = 50 bar 210 = 210 bar 350 = 350 bar 100 = 100 bar 315 = 315 bar																	
Coil voltage, see section 2 and 3: - = standard coil for 24VDC Atos drivers 6 = optional coil for 12VDC Atos drivers 18 = optional coil for low current drivers (1)																	
Coils with special connectors, see section 12: - = omit for standard DIN connector J = AMP Junior Timer connector K = Deutsch connector S = Lead Wire connection																	
Hydraulic options, see section 8: E = external pilot Y = external drain (only pipe connection G 1/4")																	

(1) select valve's coil voltage **18** in case of electronic drivers not supplied by Atos, with power supply 24V_{DC} and with max current limited to 1A.

2 ELECTRONIC DRIVERS

Drivers model	E-MI-AC		E-MI-AS-IR		E-BM-AC		E-BM-AS-PS		E-BM-AES	E-ME-AC
Type	analog		digital		analog		digital		digital	analog
Voltage supply (V _{DC})	12	24	12	24	12	24	12	24	24	24
Valve coil option	/6	std	/6	std	/6	std	/6	std	std	std
Format	DIN 43650 plug-in to solenoid				DIN 43700 UNDECAL		DIN-rail panel			EUROCARD
Data sheet	G010		G020		G025		G030		GS050	G035

3 HYDRAULIC CHARACTERISTICS (based on mineral oil ISO VG 46 at 50 °C)

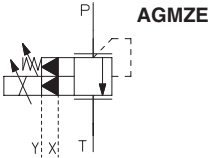
Hydraulic symbols			
Assembly position / location	Any position		
Subplate surface finishing	Roughness index Ra 0,4 - flatness ratio 0,01/100 (ISO 1101)		
Ambient temperature	Standard = -20°C ÷ +70°C; /PE option = -20°C ÷ +70°C; /BT option = -40°C ÷ +70°C		
Coil code	Standard standard coil to be used with Atos drivers with power supply 24Vdc	option /6 optional coil to be used with Atos drivers with power supply 12 Vdc	option /18 optional coil to be used with electronic drivers not supplied by Atos, with power supply 24 Vdc and max current limited to 1A
Coil resistance R at 20°C	3 ÷ 3,3 Ω	2 ÷ 2,2 Ω	13 ÷ 13,4 Ω
Max. solenoid current	2,2 A	2,75 A	1 A
Max. power	30 Watt		
Protection degree (CEI EN-60529)	IP65		
Duty factor	Continuous rating (ED=100%)		
Certification	cURus North American Standard		

Valve size	10	20	32
Max regulated pressure	50; 100; 210; 315; 350		
Min. regulated pressure [bar]	see min. pressure / flow diagrams at sect. 7		
Max. pressure at port P [bar]	350		
Max. pressure at port T [bar]	210		
Max. flow [l/min]	200	400	600
Response time 0-100% step signal (1) [ms] (depending on installation)	120	135	150
Hysteresis [% of the max pressure]	≤ 0,5		
Linearity [% of the max pressure]	≤ 1,0		
Repeatability [% of the max pressure]	≤ 0,2		

Notes: above performance data refer to valves coupled with Atos electronic drivers, see section 2.

(1) Average response time values; the pressure variation in consequence of a modification of the reference input signal to the valve is affected by the stiffness of the hydraulic circuit: greater is the stiffness of the circuit, faster is the dynamic response.

4 SEALS AND HYDRAULIC FLUID

Seals, recommended fluid temperature	NBR seals (standard) = -20°C ÷ +60°C, with HFC hydraulic fluids = -20°C ÷ +50°C FKM seals (/PE option) = -20°C ÷ +80°C HNBR seals (/BT option) = -40°C ÷ +60°C, with HFC hydraulic fluids = -40°C ÷ +50°C		
Recommended viscosity	20 ÷ 100 mm ² /s - max allowed range 15 ÷ 380 mm ² /s		
Fluid contamination class	ISO 4406 class 20/18/15 NAS 1638 class 9, in line filters of 10 μm (β10 ≥ 75 recommended)		
Hydraulic fluid	Suitable seals type	Classification	Ref. Standard
Mineral oils	NBR, FKM, HNBR	HL, HLP, HLPD, HVL, HVLDP	DIN 51524
Flame resistant without water	FKM	HF, HFDR	ISO 12922
Flame resistant with water	NBR, HNBR	HFC	

Note: For other fluids not included in above table, consult our technical office

5 GENERAL NOTES

AGMZE proportional valves are CE marked according to the applicable Directives (e.g. Immunity/Emission EMC Directive and Low Voltage Directive).

Installation, wirings and start-up procedures must be performed according to the general prescriptions shown in table F003 and in the installation notes supplied with relevant components.

6 SOLENOID CONNECTIONS

SOLENOID POWER SUPPLY CONNECTOR	
PIN	Signal description
1	SUPPLY
2	SUPPLY
3	GND

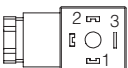

7 DIAGRAMS (based on mineral oil ISO VG 46 at 50 °C)

1 = Regulation diagrams
with flow rate Q = 50 l/min

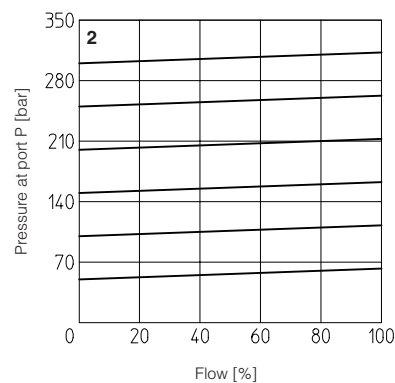
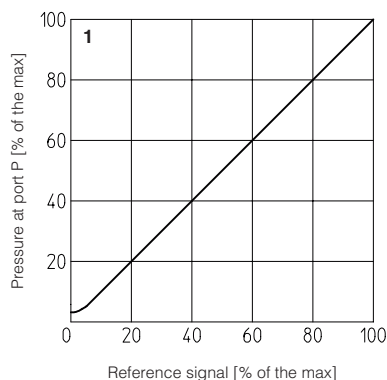

2 = Pressure/flow diagrams
with reference signal set at Q = 50 l/min

3-8 = Min. pressure/flow diagrams
with zero reference signal

- 3 = AGMZE-A-10/50, 100, 210, 315
- 4 = AGMZE-A-10/350
- 5 = AGMZE-A-20/50, 100, 210, 315
- 6 = AGMZE-A-20/350
- 7 = AGMZE-A-32/50, 100, 210, 315
- 8 = AGMZE-A-32/350

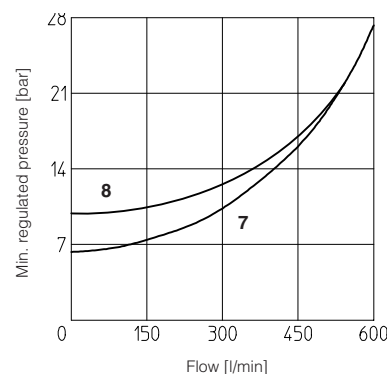
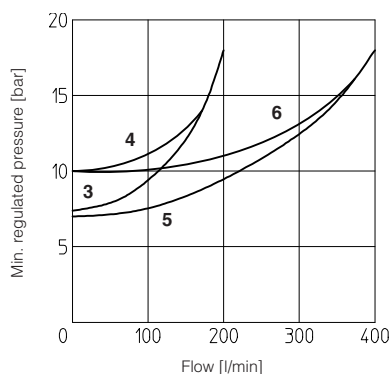

8 HYDRAULIC OPTIONS

8.1 Option E

External pilot option to be selected when the pilot pressure is supplied from a different line respect to the P main line.

With option E the internal connection between port P and X of the valve is plugged.

The pilot pressure must be connected to the X port available on the valve's mounting surface or on main body (threaded pipe connection G 1/4").

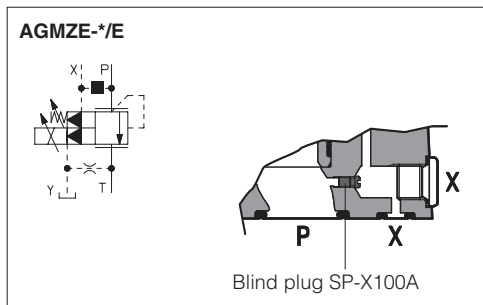

8.2 Option Y

The external drain is mandatory in case the main line T is subjected to pressure peaks or it is pressurized.

The Y drain port has a threaded connection G 1/4" available on the pilot stage body.

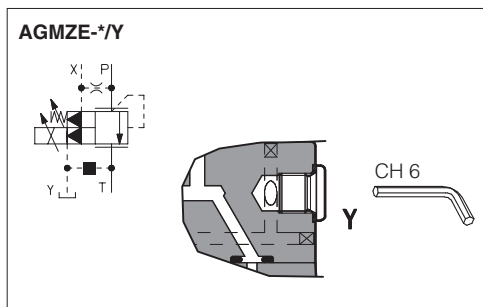

9 MECHANICAL PRESSURE LIMITER

The AGMZE are provided with mechanical pressure limiter acting as protection against overpressure. For safety reasons the factory setting of the mechanical pressure limiter is fully unloaded (min pressure).

At the first commissioning it must be set at a value lightly higher than the max pressure regulated with the proportional control.

For the pressure setting of the mechanical pressure limiter, proceed according to following steps:

- apply the max reference input signal to the valve's driver. The system pressure will not increase until the mechanical pressure limiter remains unloaded.
- turn clockwise the adjustment screw ① until the system pressure will increase up to a stable value corresponding to the pressure setpoint at max reference input signal.
- turn clockwise the adjustment screw ① of additional 1 or 2 turns to ensure that the mechanical pressure limiter remains closed during the proportional valve working.

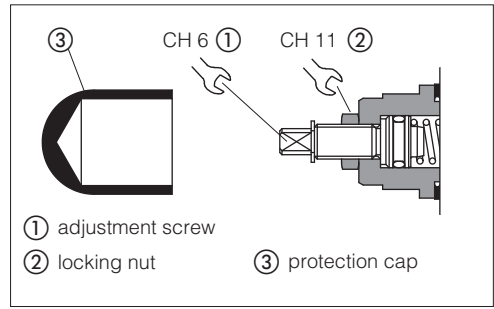

10 AIR BLEEDING

At the first valve commissioning the air eventually trapped inside the solenoid must be bled-off through the screw ① located at the rear side of the solenoid housing.

The presence of air may cause pressure instability and vibrations.



11 REMOTE PRESSURE UNLOADING

The **P** main line can be remotely unloaded by connecting the valve X port to a solenoid valve as shown in the below scheme (venting valve).

This function can be used in emergency to unload the system pressure by-passing the proportional control.

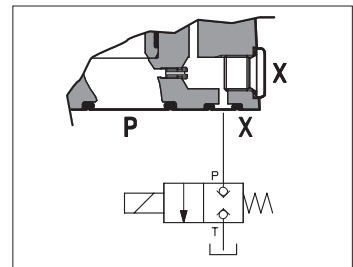

12 COILS TYPE WITH SPECIAL CONNECTORS

Options -J

Coil type COZEJ
AMP Junior Timer connector
Protection degree IP67

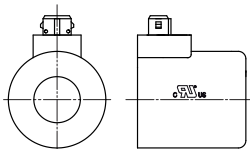

Options -K

Coil type COZEK
Deutsch connector, DT-04-2P male
Protection degree IP67

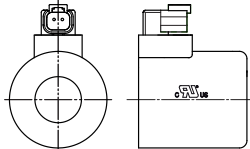

Options -S

Coil type COZES
Lead Wire connection
Cable length = 180 mm

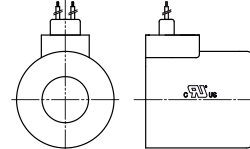

SIZE 10

ISO 6264: 2007

Mounting surface: 6264-06-09-1-97
(see table P005)

Fastening bolts: 4 socket head screws
M12x35 class 12.9

Tightening torque = 125 Nm

Seals: 2 OR 123, 1 OR 109/70

Ports P, T: $\varnothing = 14$ mm

Port X: $\varnothing = 3,2$ mm

Mass 5,4 Kg

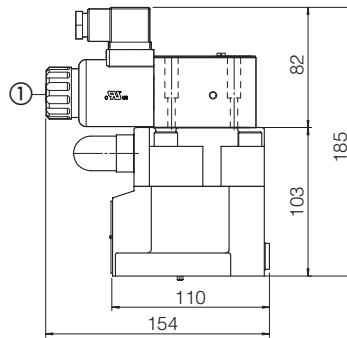

AGMZE-A-10

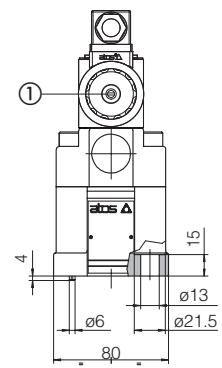

SIZE 20

ISO 6264: 2007

Mounting surface: 6264-08-13-1-97
(see table P005)

Fastening bolts: 4 socket head screws
M16x50 class 12.9

Tightening torque = 300 Nm

Seals: 2 OR 4112, 1 OR 109/70

Ports P, T: $\varnothing = 24$ mm

Port X: $\varnothing = 3,2$ mm

Mass 6,6 Kg

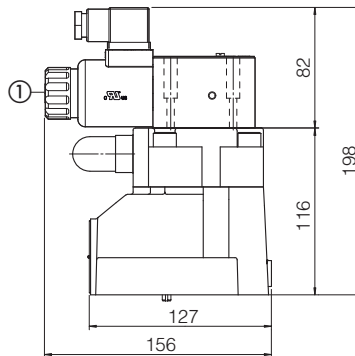

AGMZE-A-20

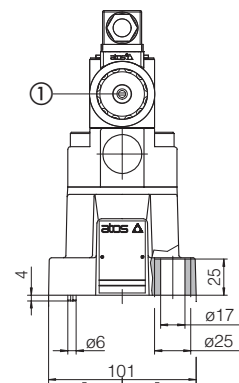

SIZE 32

ISO 6264: 2007

Mounting surface: 6264-10-17-1-97
(see table P005)

(with M20 fixing holes instead of standard M18)

Fastening bolts: 4 socket head screws
M20x60 class 12.9

Tightening torque = 600 Nm

Seals: 2 OR 4131, 1 OR 109/70

Ports P, T: $\varnothing = 28$ mm

Port X: $\varnothing = 3,2$ mm

Mass 8 Kg

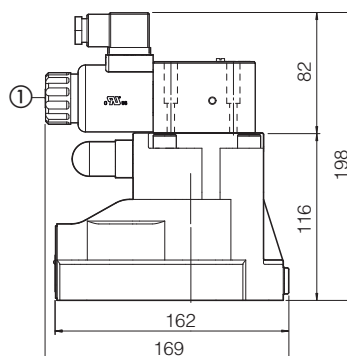

AGMZE-A-32

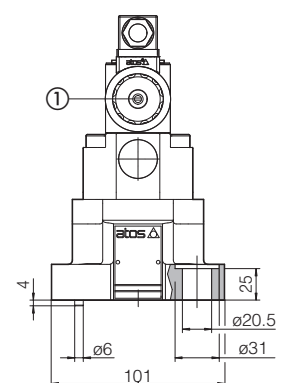

① = Screw for air bleeding