

Two stage proportional directional valves

digital, pilot operated, open loop, with positive spool overlap

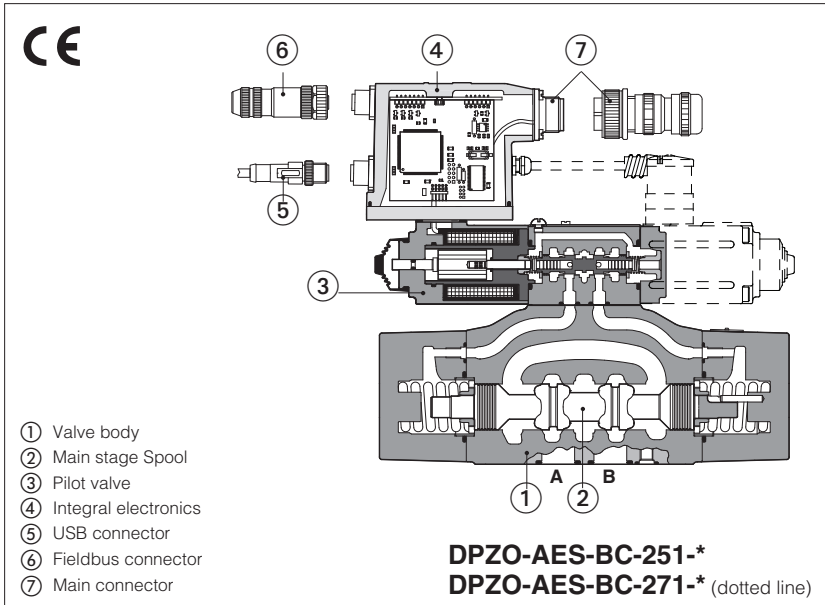

DPZO-A, DPZO-AEB, DPZO-AES

Pilot operated digital proportional valves without position transducer and with positive spool overlap, for open loop directional controls and not compensated flow regulations.

Executions:

- **A** without integral driver, to be coupled with separated drivers, see section 2
- **AEB** with basic integral digital electronic driver, analog reference signals and USB port for software functional parameters setting
- **AES** with full integral digital electronic driver and fieldbus interface for functional parameters setting, reference signals and real-time diagnostics

The integral digital electronic driver performs the valve's hydraulic regulation according to the reference signal and assures valve-to-valve interchangeability thanks to the factory presetting.

Size: **10 to 32**
 Max flow: **180 to 1500 l/min**
 Max pressure: **350 bar**

1 MODEL CODE for STANDARD SPOOLS

| | | | | | | | | | | | | | | | | | |
|--|---|---------------|-----------|--|-----------|---|----------|---|---|--|----------|--|---|---|---|---------------|---|
| DPZO | - | A | ES | - | BP | - | 2 | 71 | - | L | 5 | / | * | / | * | / | * |
| Two stage proportional directional valve | | A = open loop | | - = omit for execution with separated driver see section 2 | | EB = basic integral driver ES = full integral driver | | Fieldbus interfaces - USB port always present (1): NP = Not present BC = CANopen BP = PROFIBUS DP EH = EtherCAT | | Valve size - ISO 4401: 1 = 10 2 = 16 4 = 25 6 = 32 | | Coil voltage only for A - see sect. 9: see section 9: - = standard coil for 24V _{DC} Atos drivers 6 = optional coil for 12V _{DC} Atos drivers 18 = optional coil for low current drivers | | Seals material, see sect. 5, 6: - = NBR PE = FKM BT = HNBR | | Series number | |

Configuration (2):

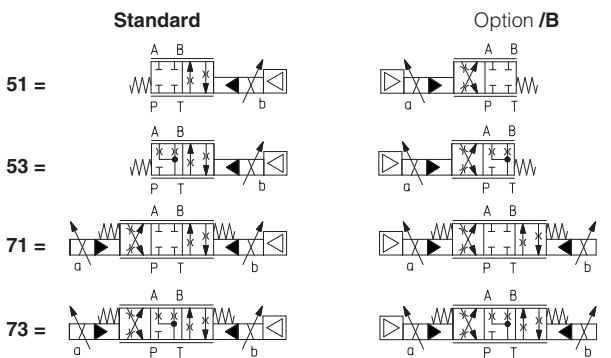

Spool type - regulating characteristics:

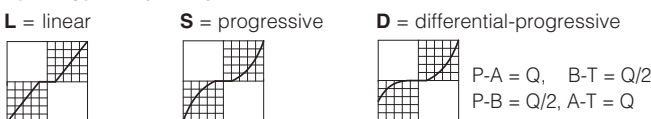

Hydraulic options, see sect. 9:

B = solenoid and integral electronics at side of port B of the main stage (side A of pilot valve) (3)

- D** = internal drain
- E** = external pilot pressure
- G** = pressure reducing valve for piloting

Electronic options, only for AEB and AES - see sect. 10

- C** = current feedback 4÷20 mA for remote transducer, only in combination with option W
- I** = current reference input 4÷20 mA (omit for standard voltage reference input ±10 V)
- Q** = enable signal
- Z** = double power supply, enable, fault and monitor signals -12 pin connector
- W** = power limitation function - 12 pin connector

| Spool size | 3 (L,S,D) | 5 (L,S,D) |
|------------|-----------|-----------|
| DPZO-1 = | - | 100 |
| DPZO-2 = | 160 | 250 |
| DPZO-4 = | - | 480 |
| DPZO-6 = | - | 640 |

Nominal flow (l/min) at Δp 10bar P-T

(1) Omit for A execution; AEB available only in version NP; AES available only in version BC, BP, EH
 (2) Hydraulic symbols are represented with integral digital driver
 (3) In standard configuration the solenoid (config. 51 and 53) and the integral electronics (AEB, AES) are at side A of the main stage (side B of pilot valve)

2 ELECTRONIC DRIVERS

| | | | | | | | | | | | | |
|-----------------------------------|---------------------|-------------------|-------------|---------------------|----------------|----------|----------|-------------------|-----|-----|------------|------------|
| Valve model | A | | | | | | | | | | AEB | AES |
| Drivers model | E-MI-AC-01F | E-BM-AC-01F | E-ME-AC-01F | E-MI-AS-IR | E-BM-AS-PS | E-BM-AES | E-RI-AEB | E-RI-AES | | | | |
| Type | Analog | | | | | Digital | | | | | | |
| Voltage supply (V _{DC}) | 12 | 24 | 12 | 24 | 24 | 12 | 24 | 12 | 24 | 24 | 24 | |
| Valve coil option | /6 | std | /6 | std | std | /6 | std | /6 | std | std | std | |
| Format | plug-in to solenoid | DIN 43700 UNDECAL | EUROCARD | plug-in to solenoid | DIN-rail panel | | | Integral to valve | | | | |
| Data sheet | G010 | G025 | G035 | G020 | G030 | GS050 | GS115 | | | | | |

Note: for main and communication connector see sections [12](#), [13](#)

3 GENERAL NOTES

DPZO-A* proportional valves are CE marked according to the applicable Directives (e.g. Immunity/Emission EMC Directive and Low Voltage Directive). Installation, wirings and start-up procedures must be performed according to the general prescriptions shown in table F003 and in the installation notes supplied with relevant components.

4 FIELDBUS - only for AES

Fieldbus allows the direct communication of the proportional valve with machine control unit for digital reference signal, diagnostics and settings of functional parameters. Analog reference signal remain available on the main connector for quick commissioning and maintenance. For detailed information about fieldbus features and specification see tech table **GS510**.

5 MAIN CHARACTERISTICS - based on mineral oil ISO VG 46 at 50 °C

| | | | |
|--|---|--|---|
| Assembly position | Any position | | |
| Subplate surface finishing | Roughness index, Ra 0,4 flatness ratio 0,01/100 (ISO 1101) | | |
| MTTFd valves according to EN ISO 13849 | 75 years, see technical table P007 | | |
| Ambient temperature range | A: standard = -20°C ÷ +70°C, AEB, AES: standard = -20°C ÷ +60°C, | /BT option = -40°C ÷ +60°C /BT option = -40°C ÷ +60°C | |
| Storage temperature range | A: standard = -20°C ÷ +80°C, AEB, AES: standard = -20°C ÷ +70°C, | /BT option = -40°C ÷ +70°C /BT option = -40°C ÷ +70°C | |
| Coil code | standard | option /6 | option /18 |
| Coil resistance R at 20°C | 3 ÷ 3,3 Ω | 2 ÷ 2,2 Ω | 13 ÷ 13,4 Ω |
| Max. solenoid current | 2,2 A | 2,75 A | 1 A |
| Max. power | A = 30W AEB, AES = 50W | | |
| Insulation class | H (180°) Due to the occurring surface temperatures of the solenoid coils, the European standards ISO 13732-1 and EN982 must be taken into account | | |
| Protection degree to DIN EN60529 | IP66/67 with mating connectors | | |
| Tropicalization | Tropical coating on electronics PCB | | |
| Duty factor | Continuous rating (ED=100%) | | |
| EMC, climate and mechanical load | See technical table G004 | | |
| Communication interface | USB Atos ASCII coding | CANopen EN50325-4 + DS408 | PROFIBUS DP EN50170-2/IEC61158 EtherCAT IEC 61158 |
| Communication physical layer | not insulated USB 2.0 + USB OTG | optical insulated CAN ISO11898 | optical insulated RS485 Fast Ethernet, insulated 100 Base TX |

| | | | | |
|---|--|-------------------|-------------------|-----------------|
| Valve model | DPZO-*-1 | DPZO-*-2 | DPZO-*-4 | DPZO-*-6 |
| Pressure limits [bar] | ports P, A, B, X = 350; T = 250 (10 for option /D); Y = 10; | | | |
| Spool type | L5, S5, D5 | L3, S3, D3 | L5, S5, D5 | |
| Nominal flow [l/min] | | | | |
| (1) Δp = 10 bar | 100 | 160 | 250 | 640 |
| Δp P-T Δp = 30 bar | 160 | 270 | 430 | 1100 |
| Max permissible flow [l/min] | 180 | 400 | 550 | 1500 |
| Piloting pressure [bar] | min. = 25; max = 350 (option /G advisable for pilot pressure > 150 bar) | | | |
| Piloting volume [cm³] | 1,4 | 3,7 | 9,0 | 21,6 |
| Piloting flow (2) [l/min] | 1,7 | 3,7 | 6,8 | 14,4 |
| Leakage (3) Main stage [l/min] | 0,15/0,5 | 0,2/0,6 | 0,3/1,0 | 1,0/3,0 |
| Response time (4) (0-100% step signal and pilot pressure 100 bar) [ms] | < 80 | < 100 | < 120 | < 180 |
| Hysteresis | ≤ 5 [% of max regulation] | | | |
| Repeatability | ± 1 [% of max regulation] | | | |

Notes: above performance data refer to valves coupled with Atos electronic drivers, see section [2](#).

(1) for different Δp, see section 7.2

(2) with step reference input signal 0 ÷ 100 %

(3) at p = 100/350 bar

(4) see detailed diagrams in section 7.3

6 SEALS AND HYDRAULIC FLUID - for other fluids not included in below table, consult our technical office

| | | | |
|--------------------------------------|---|----------------------------|----------------------|
| Seals, recommended fluid temperature | NBR seals (standard) = -20°C ÷ +60°C, with HFC hydraulic fluids = -20°C ÷ +50°C FKM seals (/PE option) = -20°C ÷ +80°C HNBR seals (/BT option) = -40°C ÷ +60°C, with HFC hydraulic fluids = -40°C ÷ +50°C | | |
| Recommended viscosity | 20 ÷ 100 mm ² /s - max allowed range 15 ÷ 380 mm ² /s | | |
| Fluid contamination class | ISO 4406 class 20/18/15 NAS 1638 class 9, in line filters of 10 µm (β ₁₀ ≥ 75 recommended) | | |
| Hydraulic fluid | Suitable seals type | Classification | Ref. Standard |
| Mineral oils | NBR, FKM, HNBR | HL, HLP, HLPD, HVLP, HVLPD | DIN 51524 |
| Flame resistant without water | FKM | HFDU, HFDR | ISO 12922 |
| Flame resistant with water | NBR, HNBR | HFC | |

7 DIAGRAMS (based on mineral oil ISO VG 46 at 50 °C)

7.1 Regulation diagrams (values measure at Δp 10 bar P-T)

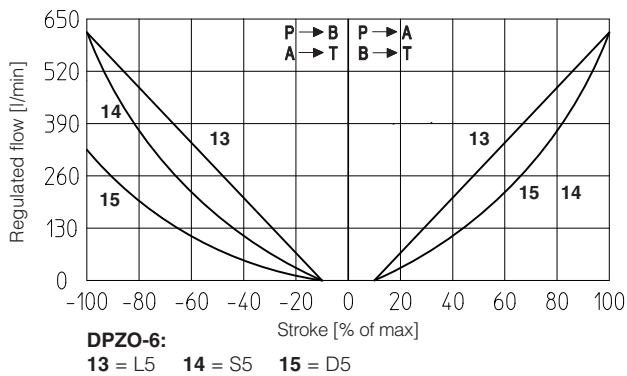
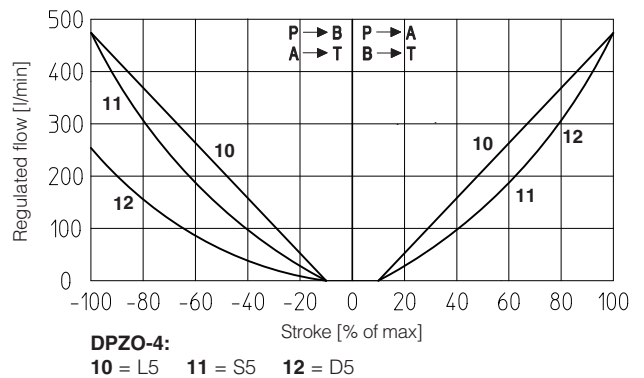
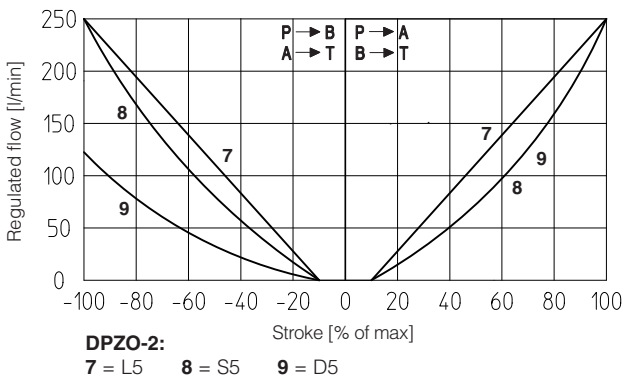
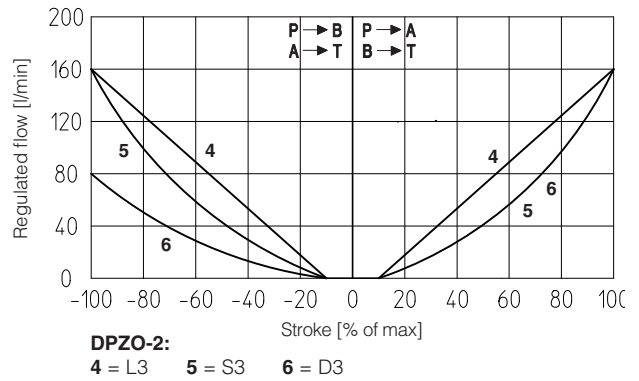
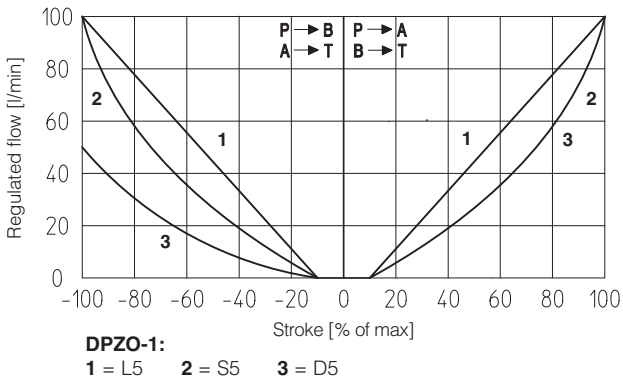

Note: Hydraulic configuration vs. reference signal for configuration 71 and 73 (standard and option /B)

Reference signal $\left. \begin{matrix} 0 \div +10 \text{ V} \\ 12 \div 20 \text{ mA} \end{matrix} \right\} P \rightarrow A / B \rightarrow T$

Reference signal $\left. \begin{matrix} 0 \div -10 \text{ V} \\ 12 \div 4 \text{ mA} \end{matrix} \right\} P \rightarrow B / A \rightarrow T$

7.2 Flow / Δp diagram

stated at 100% of spool stroke

DPZO-1:

1 = spools L5, S5, D5

DPZO-2:

2 = spools L3, S3, D3

3 = spools L5, S5, D5

DPZO-4:

4 = spools L5, S5, D5

DPZO-6:

5 = spools L5, S5, D5

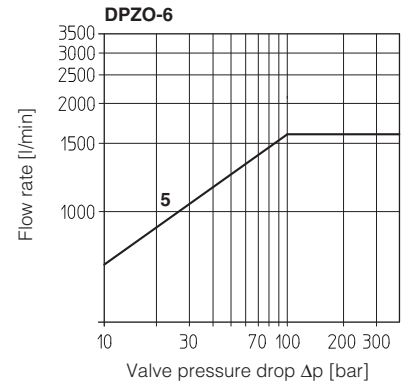
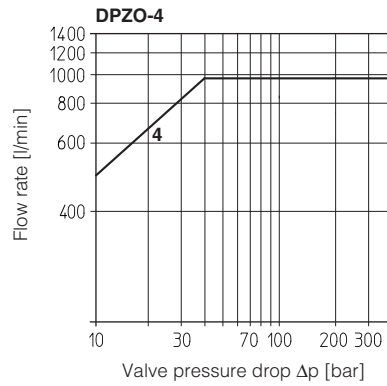
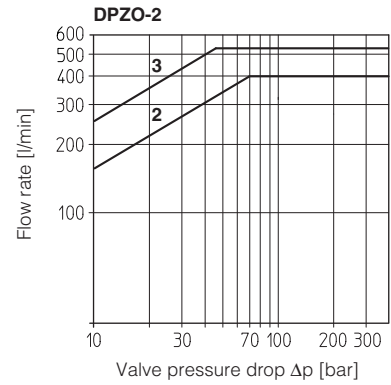
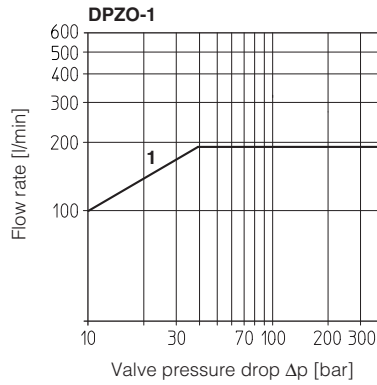

7.3 Response time (measured at pilot pressure = 100 bar)

The response times in below diagrams are measured at different steps of the reference input signal. They have to be considered as average values. For the valves with digital electronics the dynamics performances can be optimized by setting the internal software parameters.

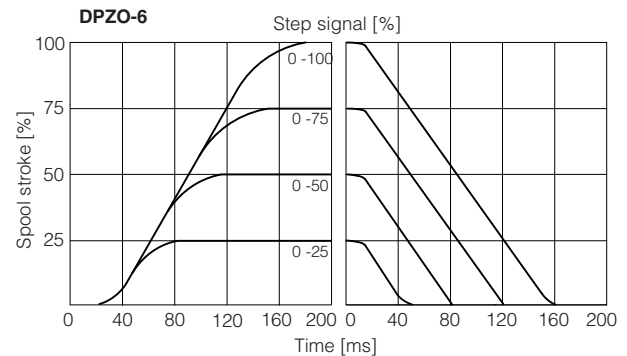
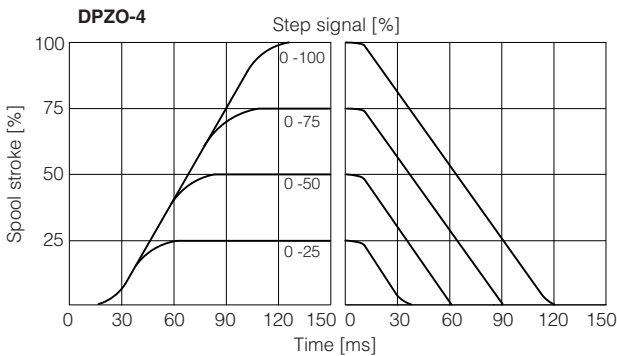
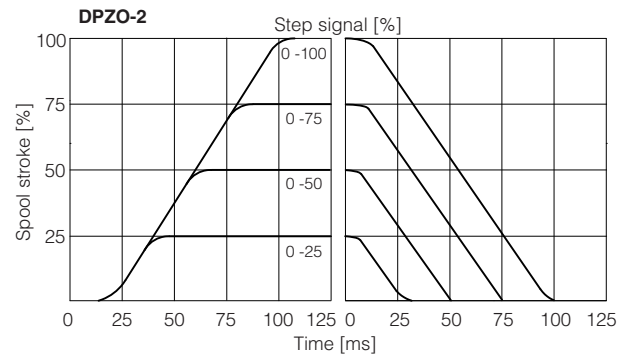
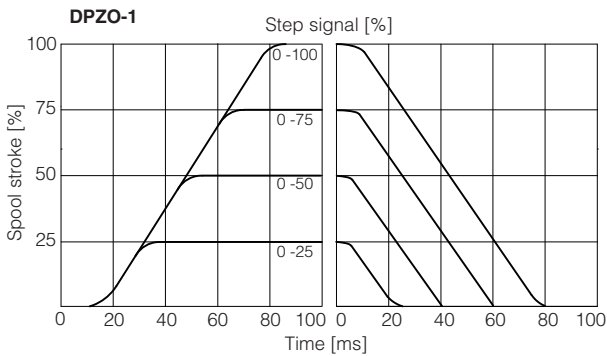

7.4 Operation as throttle valve

Single solenoid valves (*51) can be used as simple throttle valves:

$P_{max} = 250$ bar

For this application, the use of valve -TEB or -TES (see tab. FS172) is advisable (consult our technical office)

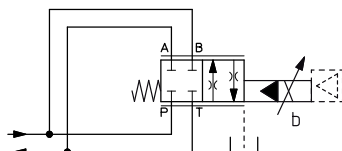

| DPZO-* | 151-L5 | 251-L5 | 451-L5 | 651-L5 |
|---------------------|--------|--------|--------|--------|
| Max flow [l/min] | 320 | 850 | 1400 | 2000 |
| $\Delta p = 30$ bar | | | | |

8 HYDRAULIC OPTIONS

8.1 Option /B

DPZO-*-5 = solenoid and integral electronics at side of port B of the main stage.

DPZO-*-7 = integral electronics at side of port B of the main stage.

8.2 Options /E and /D

Pilot and drain configuration can be modified as shown in section 15

The valve's standard configuration provides internal pilot and external drain.

For different pilot / drain configuration select:

Option /E External pilot (through port X).

Option /D Internal drain.

8.3 Option /G

Pressure reducing valve installed between pilot valve and main body with fixed setting:

DPZO-1 and -2 = 40 bar

DPZO-4 and -6 = 100 bar

It is advisable for valves with internal pilot in case of system pressure higher than 150 bar.

FUNCTIONAL SCHEME

example of configuration 7*
3 positions, spring centered

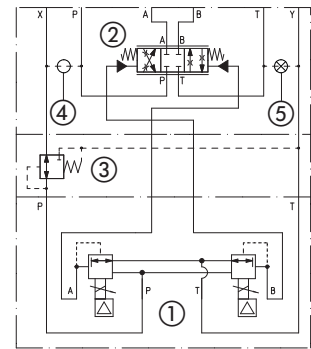

- ① Pilot valve
- ② Main stage
- ③ Pressure reducing valve
- ④ Plug to be added for external pilot trough port X
- ⑤ Plug to be removed for internal drain through port T

9 OPTIONS for -A

9.1 Coil voltage

Option /6 optional coil to be used with Atos drivers with power supply 12 V_{dc}

Option /18 optional coil to be used with electronic drivers not supplied by Atos

10 ELECTRONIC OPTIONS for AEB and AES

Standard driver execution provides on the 7 pin main connector:

Power supply - 24 V_{DC} must be appropriately stabilized or rectified and filtered; **2,5 A** fuse time lag is required in series to each driver power supply. Apply at least a 10000 µF/40 V capacitance to single phase rectifiers or a 4700 µF/40 V capacitance to three phase rectifiers

Reference input signal - analog differential input with ±10 V_{DC} nominal range (pin D, E), proportional to desired coil current

Monitor output signal - analog output signal proportional to the actual valve's coil current (1V monitor = 1A coil current)

Note: a minimum booting time of 500 ms has to be considered from the driver energizing with the 24 V_{DC} power supply before the valve has been ready to operate. During this time the current to the valve coils is switched to zero.

10.1 Option /I

It provides 4 ÷ 20 mA current reference signal, instead of the standard ±10 V.

Input signal can be reconfigured via software selecting between voltage and current, within a maximum range of ±10 V or ±20 mA.

It is normally used in case of long distance between the machine control unit and the valve or where the reference signal can be affected by electrical noise; the valve functioning is disabled in case of reference signal cable breakage.

10.2 Option /Q

To enable the driver, supply 24 V_{DC} on pin C referred to pin B: Enable input signal allows to enable/disable the current supply to the solenoid, without removing the electrical power supply to the driver; it is used to maintain active the communication and the other driver functions when the valve has to be disabled. This condition does not comply with European Norms EN13849-1 (ex EN954-1).

10.3 Option /Z

It provides, on the 12 pin main connector, the following additional features:

Enable Input Signal

To enable the driver, supply 24 V_{DC} on pin 3 referred to pin 2: Enable input signal allows to enable/disable the current supply to the solenoid, without removing the electrical power supply to the driver; it is used to maintain active the communication and the other driver functions when the valve has to be disabled. This condition does not comply with European Norms EN13849-1 (ex EN954-1).

Fault Output Signal

Fault output signal indicates fault conditions of the driver (solenoid short circuits/not connected, reference signal cable broken for 4÷20mA input, etc.). Fault presence corresponds to 0 V_{DC}, normal working corresponds to 24 V_{DC} (pin 11 referred to pin 2): Fault status is not affected by the Enable input signal

Power supply for driver's logics and communication

Separate power supply (pin 9,10) allow to cut solenoid power supply (pin 1, 2) while maintaining active diagnostics, USB and fieldbus communication.

A safety fuse is required in series to each driver power supply: 500 mA fast fuse.

10.4 Option /W - only for valves coupled with pressure compensator type KC-011 or JPC-2m (see tab. D150).

It provides, on the 12 pin main connector, the above option /Z features plus the hydraulic power limitation function.

The driver receives the flow reference signal by the analog input INPUT+ and a pressure transducer, installed in the hydraulic system, has to be connected to the driver's analog input TR.

When the actual requested hydraulic power $p \times Q$ (TR x INPUT+) reaches the max power limit ($p1 \times Q1$), internally set by software, the driver automatically reduces the flow regulation of the valve. The higher is the pressure feedback the lower is the valve's regulated flow:

$$\text{Flow regulation} = \text{Min} \left(\frac{\text{PowerLimit [sw setting]}}{\text{Transducer Pressure [TR]}} ; \text{Flow Reference [INPUT+]} \right)$$

For detailed information on hydraulic power limitation, see tab. GS115

10.5 Option /C - only in combination with option /W

Option /C is available to connect pressure transducer with 4 ÷ 20 mA current output signal, instead of the standard 0 ÷ 10V.

Input signal can be reconfigured via software selecting between voltage and current, within a maximum range of ±10 V or ±20 mA.

10.6 Possible combined options: /IQ, /IZ, /IW, /CW and /CWI

11 ELECTRONIC CONNECTIONS

11.1 Main connector signals - 7 pin - standard and /Q options - DPZO-AEB and DPZO-AES (A1)

| PIN | Standard | /Q | TECHNICAL SPECIFICATIONS | NOTES |
|-----|-----------------------------------|--------|---|--|
| A | V+ | | Power supply 24 Vdc Rectified and filtered: $V_{RMS} = 20 \div 32 V_{MAX}$ (ripple max 10 % V_{PP}) | Input - power supply |
| B | V0 | | Power supply 0 Vdc | Gnd - power supply |
| C | AGND | | Analog ground | Gnd - analog signal |
| | | ENABLE | Enable (24 Vdc) or disable (0 Vdc) the driver, referred to V0 | Input - on/off signal |
| D | INPUT+ | | Reference input signal: $\pm 10 V_{dc}$ / ± 20 mA maximum range Defaults are $\pm 10 V_{dc}$ for standard and $4 \div 20$ mA for /I option | Input - analog signal Software selectable |
| E | INPUT- | | Negative reference input signal for INPUT+ | Input - analog signal |
| F | MONITOR referred to: AGND V0 | | Monitor output signal: $\pm 5 V_{dc}$ maximum range Default is $\pm 5 V_{dc}$ (1V = 1A) | Output - analog signal Software selectable |
| G | EARTH | | Internally connected to driver housing | |

11.2 Main connector signals - 12 pin - /Z and /W options - DPZO-AEB and DPZO-AES (A2)

| PIN | /Z | /W | TECHNICAL SPECIFICATIONS | NOTES |
|-----|---------|----------|---|---|
| 1 | V+ | | Power supply 24 Vdc Rectified and filtered: $V_{RMS} = 20 \div 32 V_{MAX}$ (ripple max 10 % V_{PP}) | Input - power supply |
| 2 | V0 | | Power supply 0 Vdc | Gnd - power supply |
| 3 | ENABLE | | Enable (24 Vdc) or disable (0 Vdc) the driver, referred to V0 | Input - on/off signal |
| 4 | INPUT+ | | Reference input signal: $\pm 10 V_{dc}$ / ± 20 mA maximum range Defaults are $\pm 10 V_{dc}$ for standard and $4 \div 20$ mA for /I option | Input - analog signal Software selectable |
| 5 | INPUT- | | Negative reference input signal for INPUT+ | Input - analog signal |
| 6 | MONITOR | | Monitor output signal: $\pm 5 V_{dc}$ maximum range, referred to VLO Default is $\pm 5 V_{dc}$ (1V = 1A) | Output - analog signal |
| 7 | NC | | Do not connect | |
| 8 | NC | | Do not connect | |
| | | MONITOR2 | 2nd monitor output signal: $\pm 5 V_{dc}$ maximum range, default is $0 \div 5 V_{dc}$ | Output - analog signal |
| 9 | VL+ | | Power supply 24 Vdc for driver's logic and communication | Input - power supply |
| 10 | VLO | | Power supply 0 Vdc for driver's logic and communication | Gnd - power supply |
| 11 | FAULT | | Fault (0 Vdc) or normal working (24 Vdc), referred to V0 | Output - on/off signal |
| PE | EARTH | | Internally connected to driver housing | |

11.3 Communication connectors - DPZO-AEB (B) and DPZO-AES (B) - (C)

(B) **USB connector - M12 - 5 pin** always present

| PIN | SIGNAL | TECHNICAL SPECIFICATION (1) |
|-----|---------|-----------------------------|
| 1 | +5V_USB | Power supply |
| 2 | ID | Identification |
| 3 | GND_USB | Signal zero data line |
| 4 | D- | Data line - |
| 5 | D+ | Data line + |

(C1) **BC fieldbus execution, connector - M12 - 5 pin (2)**

| PIN | SIGNAL | TECHNICAL SPECIFICATION (1) |
|-----|----------|-----------------------------|
| 1 | CAN_SHLD | Shield |
| 2 | NC | do not connect |
| 3 | CAN_GND | Signal zero data line |
| 4 | CAN_H | Bus line (high) |
| 5 | CAN_L | Bus line (low) |

(C2) **BP fieldbus execution, connector - M12 - 5 pin (2)**

| PIN | SIGNAL | TECHNICAL SPECIFICATION (1) |
|-----|--------|---------------------------------------|
| 1 | +5V | Termination supply signal |
| 2 | LINE-A | Bus line (high) |
| 3 | DGND | Data line and termination signal zero |
| 4 | LINE-B | Bus line (low) |
| 5 | SHIELD | |

(C3) (C4) **EH fieldbus execution, connector - M12 - 4 pin (2)**

| PIN | SIGNAL | TECHNICAL SPECIFICATION (1) |
|---------|--------|-----------------------------|
| 1 | TX+ | Transmitter |
| 2 | RX+ | Receiver |
| 3 | TX- | Transmitter |
| 4 | RX- | Receiver |
| Housing | SHIELD | |

Notes: (1) shield connection on connector's housing is recommended (2) only for AES execution

11.4 Pressure transducer connector - M12 - 5 pin - only for /W option (D)

| PIN | SIGNAL | TECHNICAL SPECIFICATION | Voltage | Current |
|-----|---------|---|---------|---------|
| 1 | VF +24V | Power supply +24Vdc | Connect | Connect |
| 2 | TR | Signal transducer maximum range $\pm 10 V_{dc}$ / ± 20 mA, software selectable Defaults are $0 \div 10 V_{dc}$ for standard and $4 \div 20$ mA for /C option | Connect | Connect |
| 3 | AGND | Common GND for transducer power and signals | Connect | / |
| 4 | NC | Not Connect | / | / |
| 5 | NC | Not Connect | / | / |

11.5 Solenoid connection - only for DPZO-A

| PIN | SIGNAL | TECHNICAL SPECIFICATION | Connector code 666 |
|-----|--------|-------------------------|--------------------|
| 1 | COIL | Power supply | |
| 2 | COIL | Power supply | |
| 3 | GND | Ground | |

11.6 Connections layout - only for AEB and AES

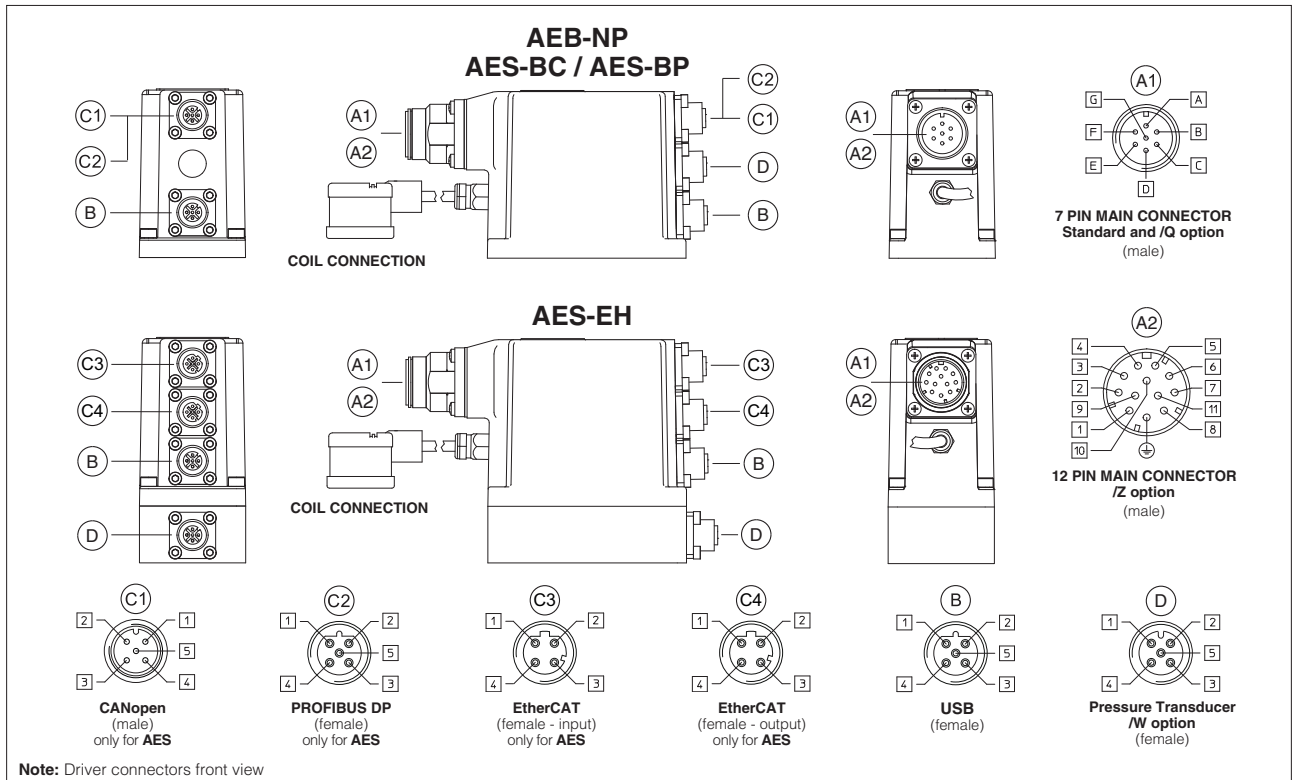

12 CONNECTORS

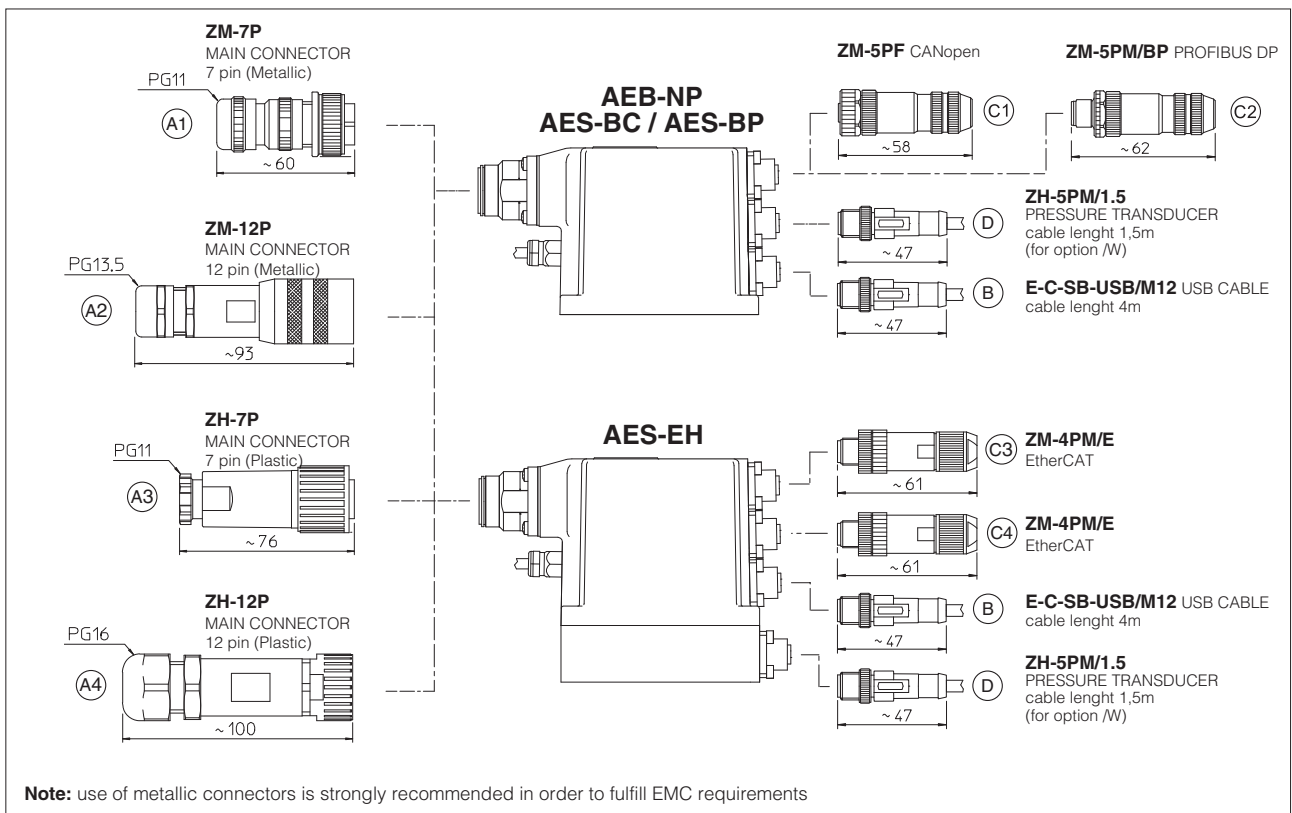

13 MODEL CODES OF MAIN CONNECTORS AND COMMUNICATION CONNECTORS - to be ordered separately

| VALVE VERSION | A (1) | AEB, AES std and /Q | AEB, AES /Z and /W | AEB, AES /W | BC - CANopen | BP - PROFIBUS DP | EH - EtherCAT |
|-------------------|-------|------------------------|-----------------------|----------------|--------------|------------------|---------------|
| CONNECTOR CODE | 666 | ZM-7P (A1) | ZM-12P (A2) | ZH-5PM/1.5 (D) | ZM-5PF (C1) | ZM-5PM/BP (C2) | ZM-4PM/E (C3) |
| | | ZH-7P (A3) | ZH-12P (A4) | | | | ZM-4PM/E (C4) |
| PROTECTION DEGREE | IP67 | IP67 | | | | | |
| DATA SHEET | K500 | GS115, K500 | | | | | |

(1) Connector supplied with the valve

only for AES

14 PROGRAMMING TOOLS - see tech table **GS500**

Valve's functional parameters and configurations, can be easily set and optimized using Atos E-SW programming software connected via USB port to the digital driver. For fieldbus versions, the software permits valve's parameterization through USB port also if the driver is connected to the central machine unit via fieldbus.

The software is available in different versions according to the driver's options

E-SW-BASIC support: NP (USB) PS (Serial) IR (Infrared)

E-SW-FIELDBUS support: BC (CANopen) BP (PROFIBUS DP) EH (EtherCAT)
EW (POWERLINK) EI (EtherNet/IP)

E-SW-*/PQ support: valves with SP, SF, SL alternated control (e.g. E-SW-BASIC/PQ)

WARNING: drivers USB port is not isolated!

The use of isolator adapter is highly recommended for PC protection (see table **GS500**)

USB connection

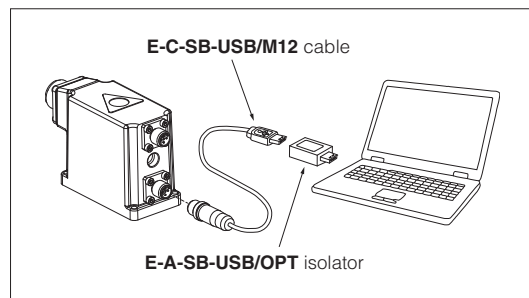

15 PLUGS LOCATION FOR PILOT/DRAIN CHANNELS

Depending on the position of internal plugs, different pilot/drain configurations can be obtained as shown below. To modify the pilot/drain configuration, proper plugs must only be interchanged. The plugs have to be sealed using loctite 270. Standard valves configuration provides internal pilot and external drain

DPZO-1 Pilot channels

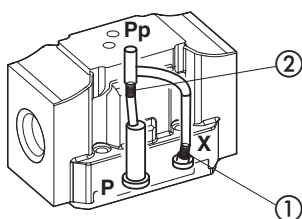

Drain channels

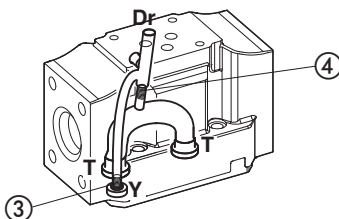

Internal piloting: blinded plug SP-X300F ① in X;
External piloting: blinded plug SP-X300F ② in Pp;
Internal drain: blinded plug SP-X300F ③ in Y;
External drain: blinded plug SP-X300F ④ in Dr.

DPZO-2 Pilot channels

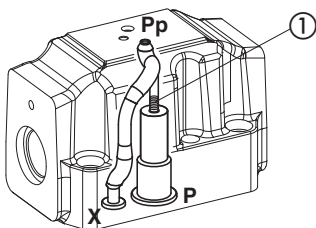

Drain channels

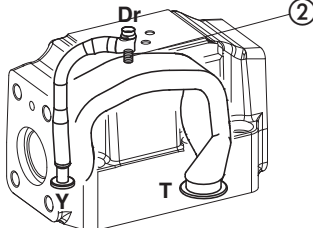

Internal piloting: Without blinded plug SP-X300F ①;
External piloting: Add blinded plug SP-X300F ①;
Internal drain: Without blinded plug SP-X300F ②;
External drain: Add blinded plug SP-X300F ②.

DPZO-4 Pilot channels

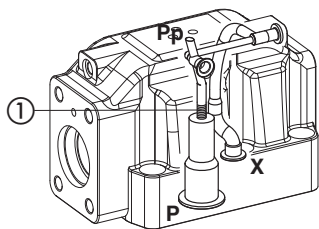

Drain channels

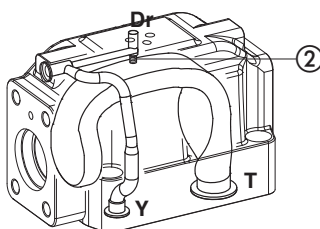

Internal piloting: Without blinded plug SP-X500F ①;
External piloting: Add blinded plug SP-X500F ①;
Internal drain: Without blinded plug SP-X300F ②;
External drain: Add blinded plug SP-X300F ②.

DPZO-6 Pilot channels

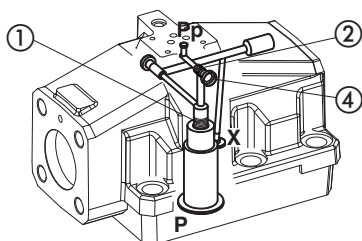

Drain channels

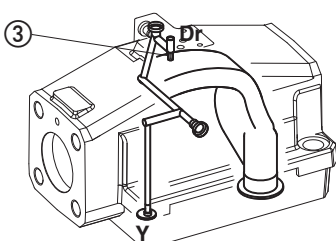

Internal piloting: Without plug ①;
External piloting: Add DIN-908 M16x1,5 in pos ①;
Add plug SP-X325A in pos ②;
Internal drain: Without blinded plug SP-X300F ③;
External drain: Add blinded plug SP-X300F ③.

To reach the orifice ② remove plug ④ = G1/8"

ISO 4401: 2005

Mounting surface: 4401-05-05-0-05 (see table P005)

Fastening bolts:

4 socket head screws M6x40 class 12.9

Tightening torque = 15 Nm

Seals: 5 OR 2050; 2 OR 108

Diameter of ports A, B, P, T: $\varnothing = 11$ mm;

Diameter of ports X, Y: $\varnothing = 5$ mm;

Mass [kg]

| | A | AEB, AES | AES-EH |
|------------|------|----------|--------|
| DPZO-*-15* | 7,7 | 8,1 | 8,2 |
| DPZO-*-17* | 8,6 | 9 | 9,1 |
| Option /G | +0,9 | | |

DPZO-A-1

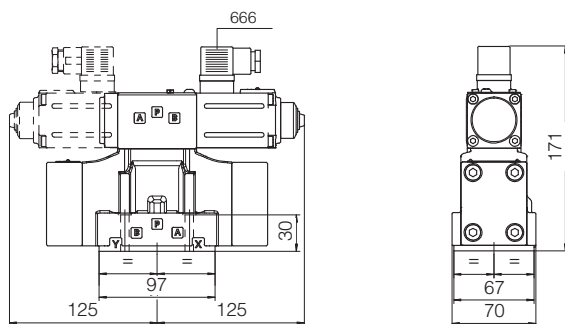

DPZO-AEB-NP-1

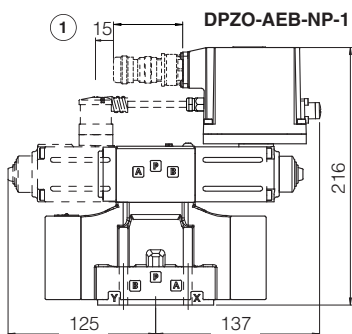

DPZO-AES-BC-1
DPZO-AES-BP-1

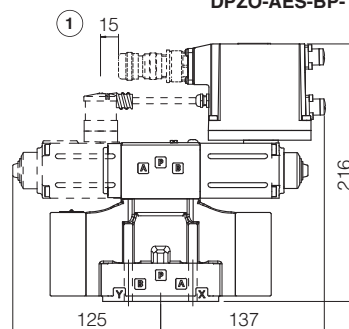

DPZO-AES-EH-1

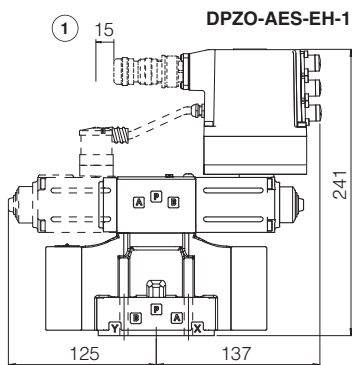

option /G

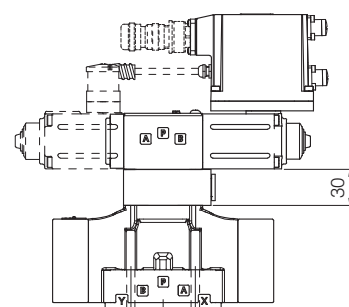

Dotted line = double solenoid version

① = Space to remove the 7 or 12 pin main connector. For main and communication connector see section 12, 13

ISO 4401: 2005

Mounting surface: 4401-07-07-0-05 (see table P005)

Fastening bolts:

4 socket head screws M10x50 class 12.9

Tightening torque = 70 Nm

2 socket head screws M6x45 class 12.9

Tightening torque = 15 Nm

Seals: 4 OR 130; 3 OR 109/70

Diameter of ports A, B, P, T: $\varnothing = 20$ mm;

Diameter of ports X, Y: $\varnothing = 7$ mm;

Mass [kg]

| | A | AEB, AES | AES-EH |
|------------|------|----------|--------|
| DPZO-*-25* | 11,9 | 12,3 | 12,4 |
| DPZO-*-27* | 12,8 | 13,2 | 13,3 |
| Option /G | +0,9 | | |

DPZO-A-2

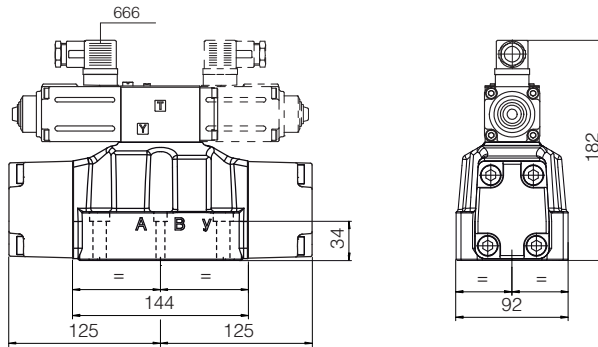

DPZO-AEB-NP-2

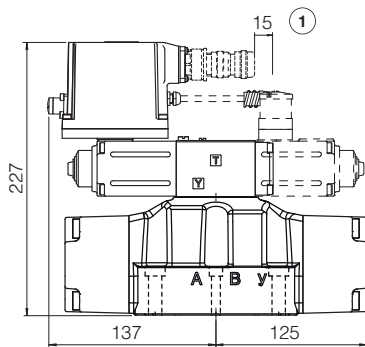

**DPZO-AES-BC-2
DPZO-AES-BP-2**

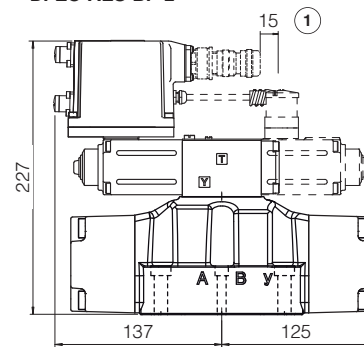

DPZO-AES-EH-2

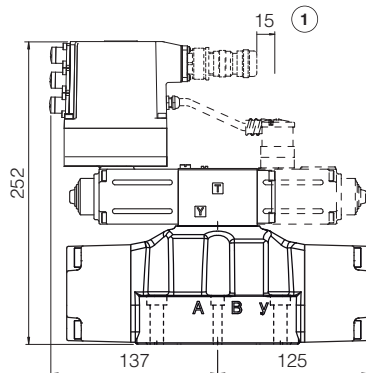

option /G

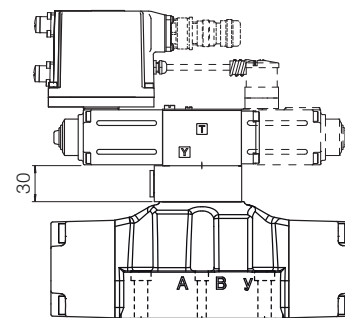

Dotted line = double solenoid version

① = Space to remove the 7 or 12 pin main connector. For main and communication connector see section 12, 13

ISO 4401: 2005

Mounting surface: 4401-08-08-0-05 (see table P005)

Fastening bolts:

6 socket head screws M12x60 class 12.9

Tightening torque = 125 Nm

Seals: 4 OR 4112; 2 OR 3056

Diameter of ports A, B, P, T: $\varnothing = 24$ mm;

Diameter of ports X, Y: $\varnothing = 7$ mm;

Mass [kg]

| | A | AEB, AES | AES-EH |
|-----------|------|----------|--------|
| DPZO*-45* | 17,1 | 18 | 18,1 |
| DPZO*-47* | 18 | 18,9 | 19 |
| Option /G | +0,9 | | |

DPZO-A-4

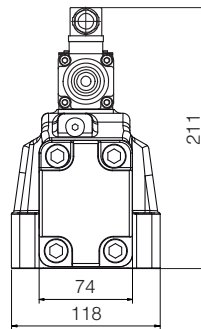
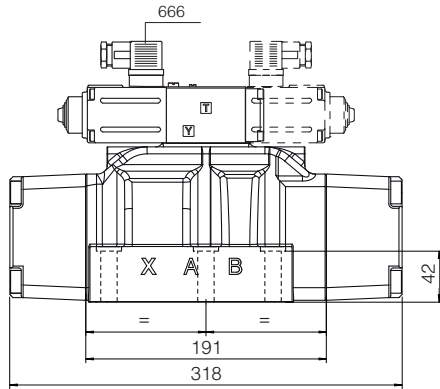

DPZO-AEB-NP-4

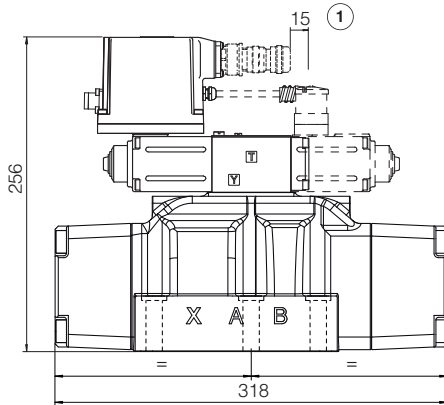

DPZO-AES-BC-4
DPZO-AES-BP-4

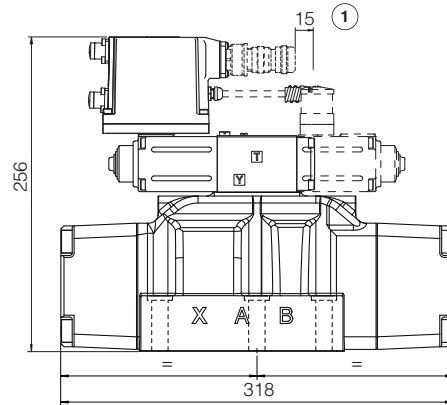

DPZO-AES-EH-4

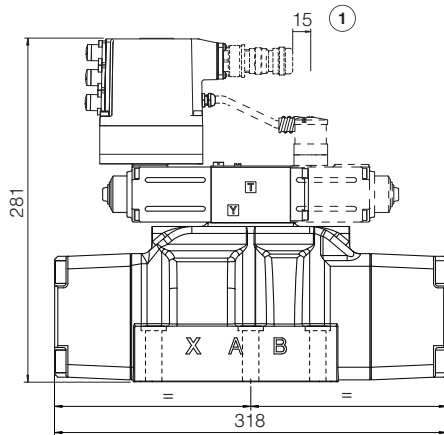

option /G

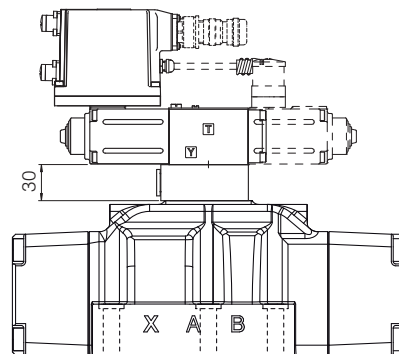

Dotted line = double solenoid version

① = Space to remove the 7 or 12 pin main connector. For main and communication connector see section 12, 13

ISO 4401: 2005

Mounting surface: 4401-10-09-0-05

Fastening bolts:

6 socket head screws M20x90 class 12.9

Tightening torque = 600 Nm

Diameter of ports A, B, P, T: $\varnothing = 34$ mm;

Diameter of ports X, Y: $\varnothing = 7$ mm;

Seals: 4 OR 144, 3 OR 3056

Mass [kg]

| | A | AEB, AES | AES-EH |
|------------|------|----------|--------|
| DPZO-*-65* | 42,1 | 42,5 | 42,6 |
| DPZO-*-67* | 42,7 | 43,1 | 43,2 |
| Option /G | | +2,3 | |

DPZO-A-6

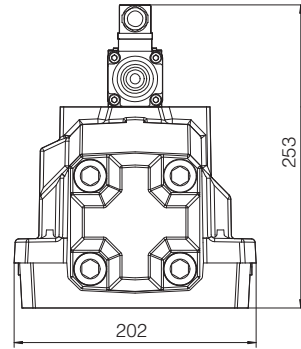
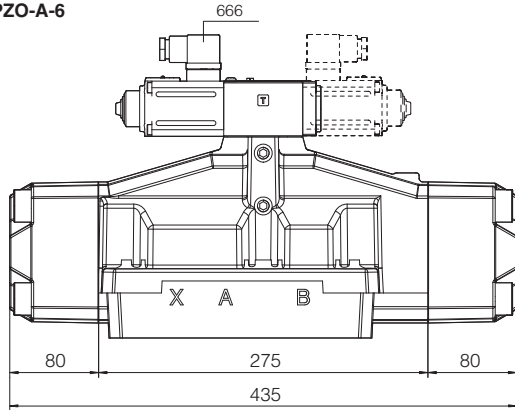

DPZO-AEB-NP-6

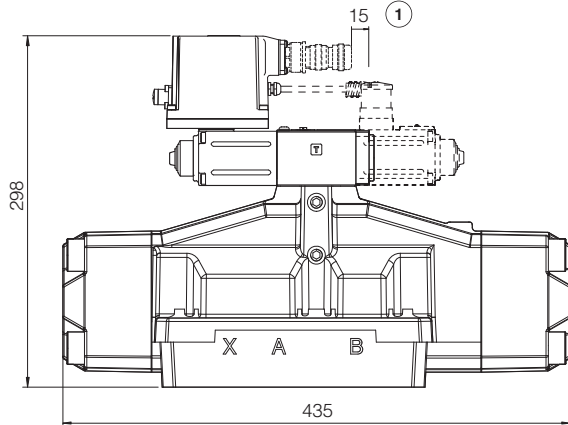

DPZO-AES-BC-6
DPZO-AES-BP-6

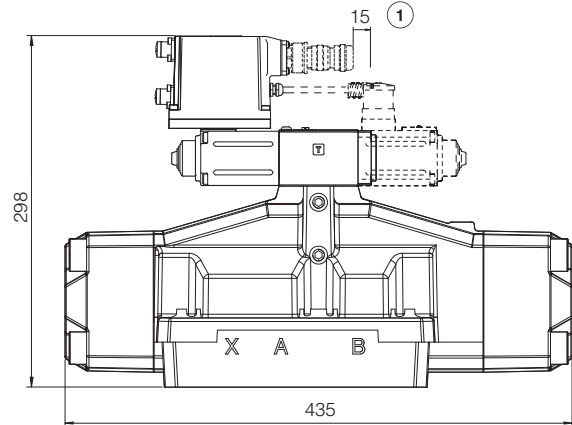

DPZO-AES-EH-6

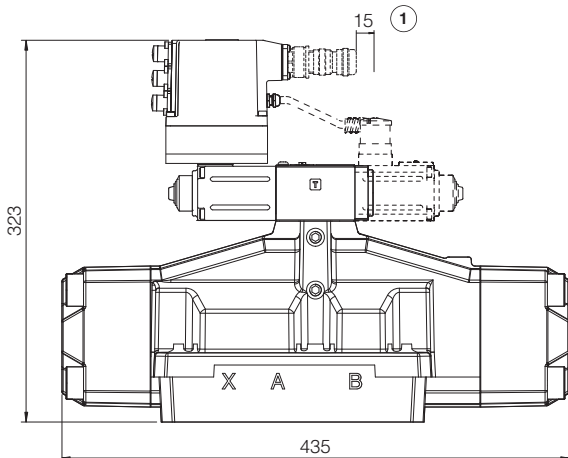

option /G

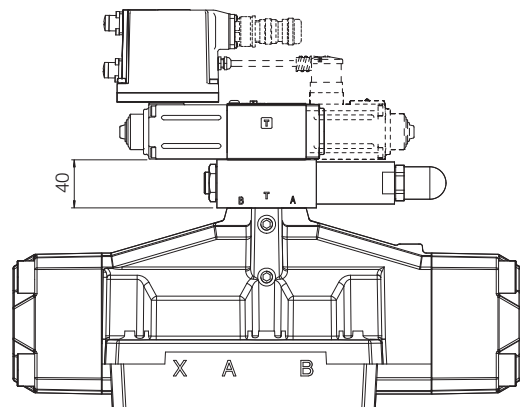

Dotted line = double solenoid version

(1) = Space to remove the 7 or 12 pin main connector. For main and communication connector see section 12, 13