

Proportional flow valves

digital, pressure compensated, direct operated, open loop

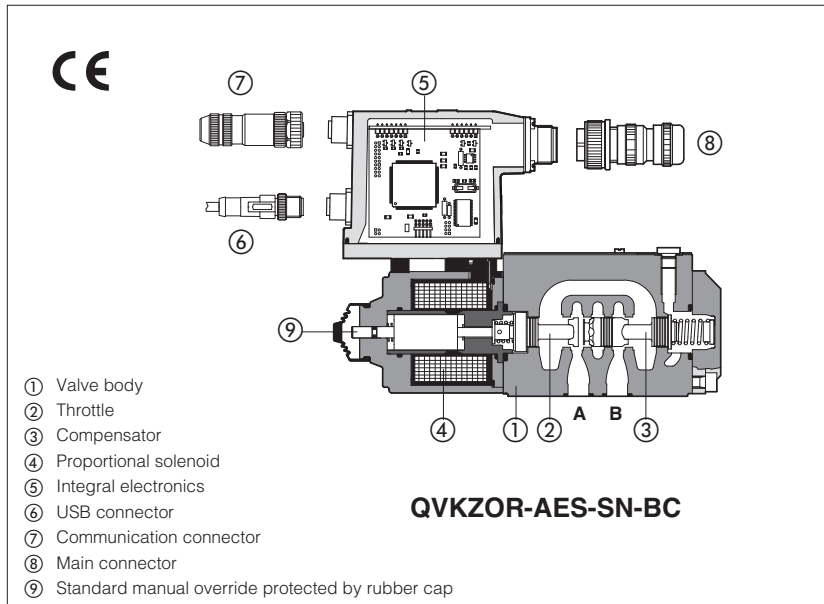

- ① Valve body
- ② Throttle
- ③ Compensator
- ④ Proportional solenoid
- ⑤ Integral electronics
- ⑥ USB connector
- ⑦ Communication connector
- ⑧ Main connector
- ⑨ Standard manual override protected by rubber cap

QVHZO-A, QVHZO-AEB, QVHZO-AES QVKZOR-A, QVKZOR-AEB, QVKZOR-AES

Pressure compensated, proportional flow control valves, direct operated, without position transducer for open loop flow regulations.

Executions:

- **A** without integral driver, to be coupled with separated drivers, see section 2.
- **AEB** with basic integral digital electronic driver, analog reference signals and USB port for software functional parameters setting.
- **AES** with full integral digital electronic driver and fieldbus interface for functional parameters setting, reference signals and real-time diagnostics.

The integral digital electronic driver performs the valve's hydraulic regulation according to the reference signal and assures valve-to-valve interchangeability thanks to the factory presetting.

Sizes: **06** and **10**
Max flow: up to **45** and **90 l/min**
Max pressure: **210 bar**

1 MODEL CODE

QVKZOR	-	A	-	ES	-	NP	-	10	/	65	/	*	/	*	/	**	/	*	
Pressure compensated flow control valves																		Seals material, see sec. 5, 6:	
QVHZO = size 06																		- = NBR	
QVKZOR = size 10																		PE = FKM	
A = open loop																		BT = HNBR	
- = omit for execution with separated driver see section 2																		Coil voltage only for A - see section 10:	
EB = basic integral driver																		- = standard coil for 24V _{DC} Atos drivers	
ES = full integral driver																		6 = optional coil for 12V _{DC} Atos drivers	
Fieldbus interfaces USB port always present (1):																		18 = optional coil for low current drivers	
NP = Not present																		Hydraulic options - see sect. 9:	
BC = CANopen																		D = quick venting of port B	
Valve size																		Hand lever options, only for QVHZO-A - see sect. 10:	
06 = ISO 4401, size 06																		MO = horizontal hand lever	
10 = ISO 4401, size 10																		MV = vertical hand lever	
Max regulated flow:																		Electronic options, only for AEB, AES - see sect. 11:	
QVHZO:																		C = current feedback 4÷20 mA for remote transducer, only in combination with option W	
3 = 3,5 l/min																		I = current reference input 4÷20 mA	
36 = 35 l/min																		(omit for standard voltage reference input ±10 V)	
12 = 12 l/min																		Q = enable signal	
45 = 45 l/min																		Z = double power supply, enable, fault and monitor signals - 12 pin connector	
18 = 18 l/min																		W = Power limitation function - 12 pin connector	

(1) Omit for **A** execution; **AEB** available only in version **NP**; **AES** available only in version **BC, BP, EH**

Hydraulic symbols (2)

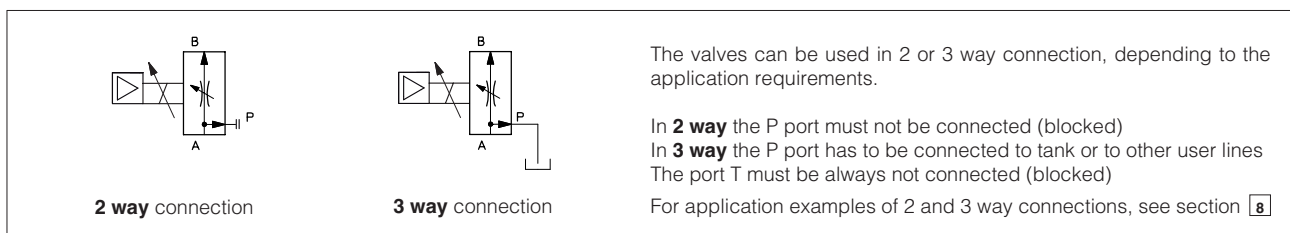

(2) Hydraulic symbols are represented with integral digital driver

2 ELECTRONIC DRIVERS

Valve model	A										AEB	AES
Drivers model	E-MI-AC-01F	E-BM-AC-01F	E-ME-AC-01F	E-MI-AS-IR	E-BM-AS-PS	E-BM-AES	E-RI-AEB	E-RI-AES				
Type	Analog					Digital						
Voltage supply (V_{oc})	12	24	12	24	24	12	24	12	24	24	24	
Valve coil option	/6	std	/6	std	std	/6	std	/6	std	std	std	
Format	plug-in to solenoid	DIN 43700 UNDECAL		EUROCARD	plug-in to solenoid	DIN-rail panel				Integral to valve		
Data sheet	G010		G025		G035	G020		G030		GS050		GS115

Note: For main and communication connector see sections [13](#) [14](#)

3 GENERAL NOTES

QVHZO-A* and QVKZOR-A* proportional valves are CE marked according to the applicable Directives (e.g. Immunity/Emission EMC Directive and Low Voltage Directive). Installation, wirings and start-up procedures must be performed according to the general prescriptions shown in table F003 and in the installation notes supplied with relevant components.

4 FIELDBUS - only for AES

Fieldbus allows valve direct communication with machine control unit for digital reference, valve diagnostics and settings. These execution allow to operate the valves through fieldbus or analog signals available on the main connector. For detailed information about fieldbus features and specification see tech table **GS510**.

5 MAIN CHARACTERISTICS - based on mineral oil ISO VG 46 at 50 °C

Assembly position	Any position						
Subplate surface finishing	Roughness index, Ra 0,4 flatness ratio 0,01/100 (ISO 1101)						
MTTFd valves according to EN ISO 13849	150 years, see technical table P007						
Ambient temperature range	A: standard = -20°C ÷ +70°C,			/BT option = -40°C ÷ +60°C			
	AEB, AES: standard = -20°C ÷ +60°C,			/BT option = -40°C ÷ +60°C			
Storage temperature range	A: standard = -20°C ÷ +80°C,			/BT option = -40°C ÷ +70°C			
	AEB, AES: standard = -20°C ÷ +70°C,			/BT option = -40°C ÷ +70°C			
Coil code	QVHZO			QVKZOR			
	standard	option /6	option /18	standard	option /6	option /18	
Coil resistance R at 20°C	3 ÷ 3,3 Ω	2 ÷ 2,2 Ω	13 ÷ 13,4 Ω	3,8 ÷ 4,1 Ω	2,2 ÷ 2,4 Ω	12 ÷ 12,5 Ω	
Max. solenoid current	2,2 A	2,75 A	1,2 A	2,6 A	3,25 A	1,2 A	
Max. power	A = 30W		AEB, AES = 50W		A = 35W		AEB, AES = 50W
Insulation class	H (180°) Due to the occurring surface temperatures of the solenoid coils, the European standards ISO 13732-1 and EN982 must be taken into account						
Protection degree to DIN EN60529	IP66/67 with mating connectors						
Tropicalization	Tropical coating on electronics PCB						
Duty factor	Continuous rating (ED=100%)						
EMC, climate and mechanical load	See technical table G004						
Communication interface	USB Atos ASCII coding		CANopen EN50325-4 + DS408		PROFIBUS DP EN50170-2/IEC61158		EtherCAT IEC 61158
Communication physical layer	not insulated USB 2.0 + USB OTG		optical insulated CAN ISO11898		optical insulated RS485		Fast Ethernet, insulated 100 Base TX

Valve model	QVHZO						QVKZOR	
Max regulated flow [l/min]	3,5	12	18	35	45	65	90	
Min regulated flow [cm³/min]	15	20	30	50	60	85	100	
Regulating Δp [bar]	4 - 6		10 - 12			15	6 - 8 10 - 12	
Max flow on port A [l/min]	40			50	55	70	100	
Max pressure [bar]	210							
Response time 0÷100% step signal [ms]	30						45	
Hysteresis [% of the regulated max flow]	≤ 5							
Linearity [% of the regulated max flow]	≤ 3							
Repeatability [% of the regulated max flow]	≤ 1							

Notes: above performance data refer to valves coupled with Atos electronic drivers, see section [2](#)

6 SEALS AND HYDRAULIC FLUID - for other fluids not included in below table, consult our technical office

Seals, recommended fluid temperature	NBR seals (standard) = -20°C ÷ +60°C, with HFC hydraulic fluids = -20°C ÷ +50°C FKM seals (/PE option) = -20°C ÷ +80°C HNBR seals (/BT option) = -40°C ÷ +60°C, with HFC hydraulic fluids = -40°C ÷ +50°C		
Recommended viscosity	20 ÷ 100 mm ² /s - max allowed range 15 ÷ 380 mm ² /s		
Fluid contamination class	ISO 4406 class 20/18/15 NAS 1638 class 9, in line filters of 10 µm (β ₁₀ ≥ 75 recommended)		
Hydraulic fluid	Suitable seals type	Classification	Ref. Standard
Mineral oils	NBR, FKM, HNBR	HL, HLP, HLPD, HVLP, HVLPD	DIN 51524
Flame resistant without water	FKM	HFDU, HFDR	ISO 12922
Flame resistant with water	NBR, HNBR	HFC	

7 DIAGRAMS - based on mineral oil ISO VG 46 at 50 °C

7.1 Regulation diagrams

- 1 = QVHZO-*-06/3
- 2 = QVHZO-*-06/12
- 3 = QVHZO-*-06/18
- 4 = QVHZO-*-06/36
- 5 = QVHZO-*-06/45
- 6 = QVKZOR-*-10/65
- 7 = QVKZOR-*-10/90

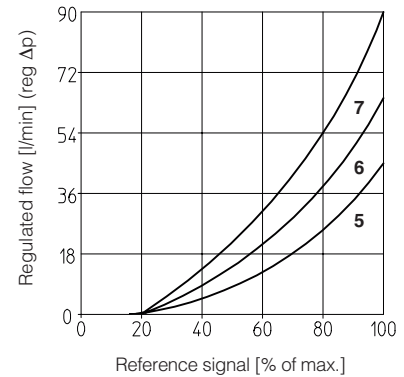
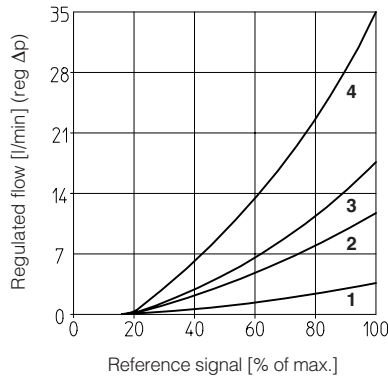

7.2 Regulated flow/outlet pressure diagrams
with inlet pressure = 210 bar

- 1 = QVHZO
- 2 = QVKZOR

Dotted line for 3-way versions

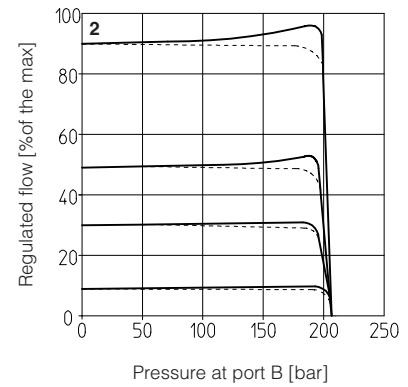
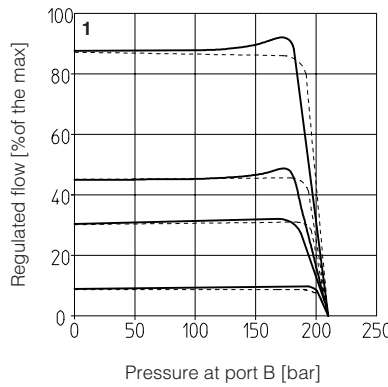

7.3 Flow A → P/Δp diagrams
3-way configuration

- 1 = QVHZO-*-06/3
- 2 = QVHZO-*-06/12
- 3 = QVHZO-*-06/18
- 4 = QVHZO-*-06/36
- 5 = QVHZO-*-06/45
- 6 = QVKZOR-*-10/65
- 7 = QVKZOR-*-10/90

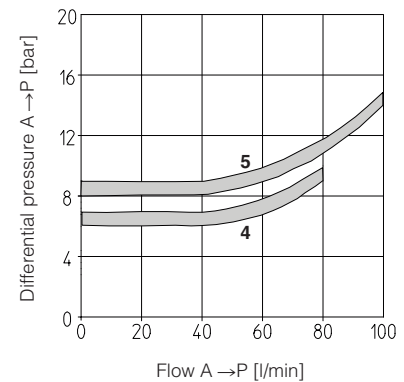
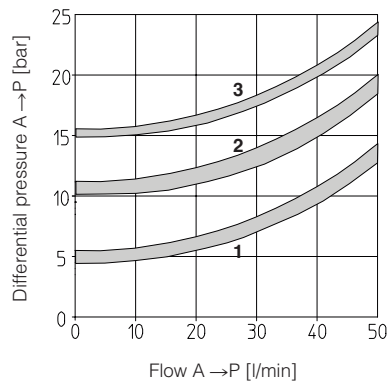

8 APPLICATIONS AND CONNECTIONS

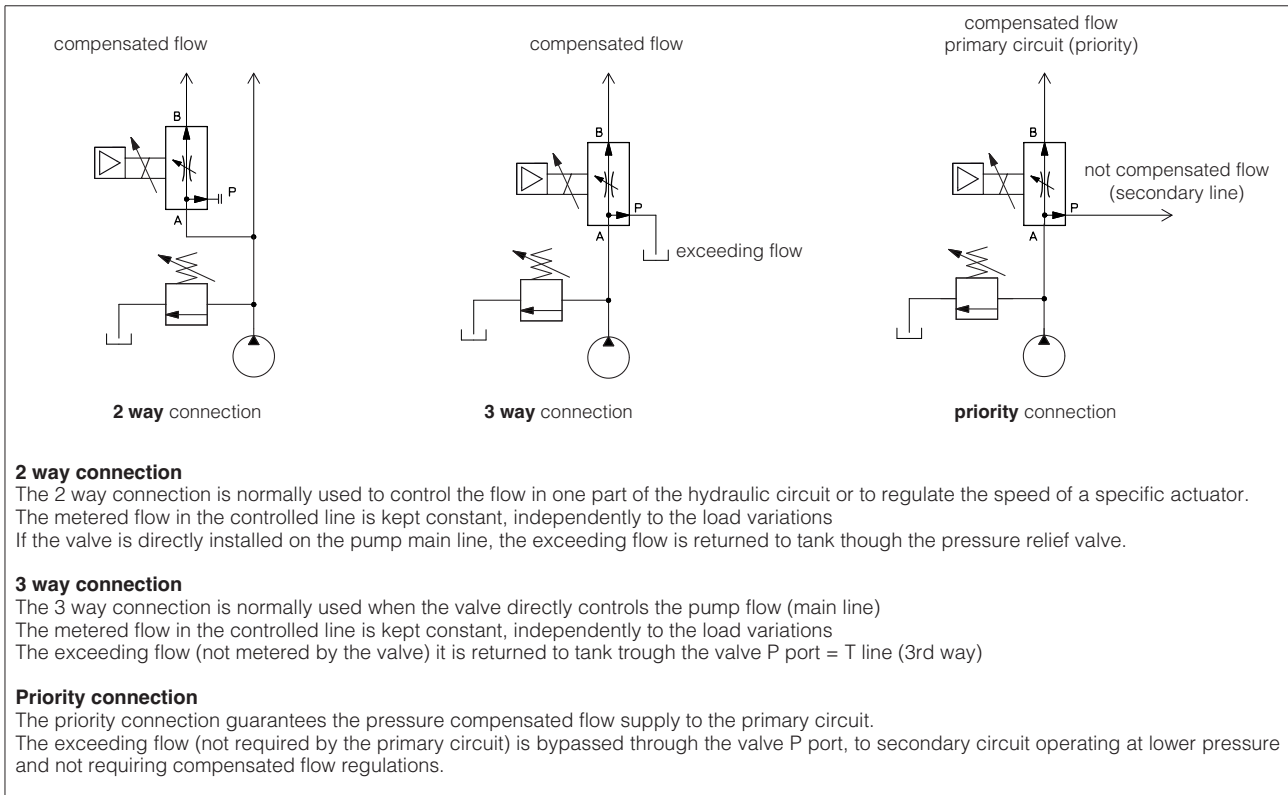

9 HYDRAULIC OPTIONS

9.1 Option /D

This option provides a quick venting of the use port B when the valve is closed or de-energized. The valve must be connected in 3 way, with P port connected to tank. When the proportional throttle is fully closed, the valve's port B is internally connected to port P (tank), permitting a quickly decompression of the pressure in the use line. In the diagram aside are represented the venting times of **QVHZO** and **QVKZOR** option /D respect to standard versions.

- 1 = standard versions
- 2 = option /Q

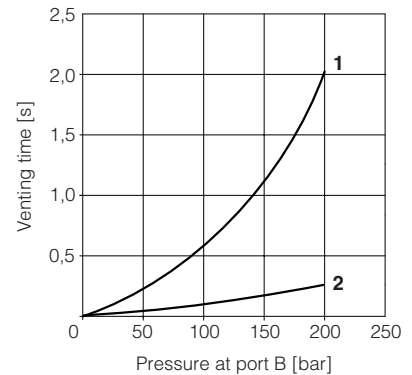

10 OPTIONS for -A

10.1 Coil voltage

- Option /6** optional coil to be used with Atos drivers with power supply 12 VDC
- Option /18** optional coil to be used with electronic drivers not supplied by Atos

10.2 Hand lever only for QVHZO-A

It allows to operate the valve in absence of electrical power supply. For detailed description of QVHZO-A with hand lever option see tech. table E138

- Option /MO** horizontal hand lever
- Option /MV** vertical hand lever

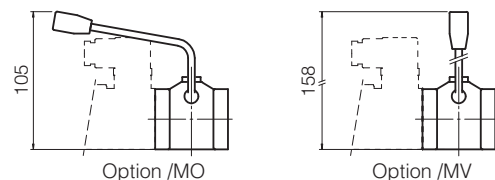

The following supplementary options allow to operate **QVHZO-A** and **QVKZOR-A** in absence of electrical power supply by means of a micrometric screw replacing the standard solenoid manual override, see tech. table TK150

- Option /N** manual micrometric adjustment
- Option /NV** as /N plus handwheel and graduated scale

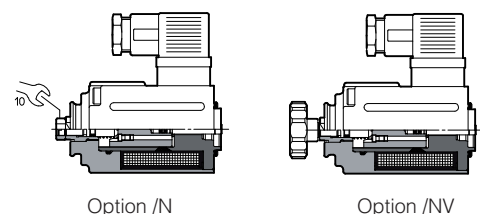

11 ELECTRONIC OPTIONS for AEB and AES

Standard driver execution provides on the 7 pin main connector:

Power supply - 24 VDC must be appropriately stabilized or rectified and filtered; **2,5 A** fuse time lag is required in series to each driver power supply. Apply at least a 10000 μ F/40 V capacitance to single phase rectifiers or a 4700 μ F/40 V capacitance to three phase rectifiers

Reference input signal - analog differential input with ± 10 VDC nominal range (pin D, E), proportional to desired coil current

Monitor output signal - analog output signal proportional to the actual valve's coil current (1V monitor = 1A coil current)

Note: a minimum booting time of 500 ms has been considered from the driver energizing with the 24 VDC power supply before the valve has been ready to operate. During this time the current to the valve coils is switched to zero.

11.1 Option /I

It provides 4 \div 20 mA current reference signal, instead of the standard 0 \div +10 V.

Input signal can be reconfigured via software selecting between voltage and current, within a maximum range of ± 10 V or ± 20 mA.

It is normally used in case of long distance between the machine control unit and the valve or where the reference signal can be affected by electrical noise; the valve functioning is disabled in case of reference signal cable breakage.

11.2 Option /Q

To enable the driver, supply 24 VDC on pin C referred to pin B: Enable input signal allows to enable/disable the current supply to the solenoid, without removing the electrical power supply to the driver; it is used to maintain active the communication and the other driver functions when the valve has to be disabled. This condition does not comply with European Norms EN13849-1 (ex EN954-1).

11.3 Option /Z

It provides, on the 12 pin main connector, the following additional features:

Enable Input Signal

To enable the driver, supply 24 VDC on pin 3 referred to pin 2: Enable input signal allows to enable/disable the current supply to the solenoid, without removing the electrical power supply to the driver; it is used to maintain active the communication and the other driver functions when the valve has to be disabled. This condition does not comply with European Norms EN13849-1 (ex EN954-1).

Fault Output Signal

Fault output signal indicates fault conditions of the driver (solenoid short circuits/not connected, reference signal cable broken for 4 \div 20mA input, etc.). Fault presence corresponds to 0 VDC, normal working corresponds to 24 VDC (pin 11 referred to pin 2): Fault status is not affected by the Enable input signal

Power supply for driver's logics and communication

Separate power supply (pin 9,10) allow to cut solenoid power supply (pin 1,2) while maintaining active diagnostics, USB and fieldbus communication. A safety fuse is required in series to each driver power supply: 500 mA fast fuse.

11.4 Option /W

It provides, on the 12 pin main connector, the above option /Z features plus the hydraulic power limitation function.

The driver receives the flow reference signal by the analog input INPUT+ and a pressure transducer, installed in the hydraulic system, has to be connected to the driver's analog input TR.

When the actual requested hydraulic power **p \times Q** (TR \times INPUT+) reaches the max power limit (p1 \times Q1), internally set by software, the driver automatically reduces the flow regulation of the valve. The higher is the pressure feedback the lower is the valve's regulated flow:

$$\text{Flow regulation} = \text{Min} \left(\frac{\text{PowerLimit [sw setting]}}{\text{Transducer Pressure [TR]}} ; \text{Flow Reference [INPUT+]} \right)$$

For detailed information on hydraulic power limitation, see tab. GS115

11.5 Option /C - only in combination with option /W

Option /C is available to connect pressure transducer with 4 \div 20 mA current output signal, instead of the standard 0 \div 10V.

Input signal can be reconfigured via software selecting between voltage and current, within a maximum range of ± 10 V or ± 20 mA.

11.6 Possible combined options: /IQ, /IZ, /IW, /CW and /CWI

12 PROGRAMMING TOOLS - see tech table GS500

Valve's functional parameters and configurations, can be easily set and optimized using Atos E-SW programming software connected via USB port to the digital driver. For fieldbus versions, the software permits valve's parameterization through USB port also if the driver is connected to the central machine unit via fieldbus.

The software is available in different versions according to the driver's options:

E-SW-BASIC support: NP (USB) PS (Serial) IR (Infrared)

E-SW-FIELDBUS support: BC (CANopen) BP (PROFIBUS DP) EH (EtherCAT)
EW (POWERLINK) EI (EtherNet/IP)

E-SW-*/PQ support: valves with SP, SF, SL alternated control (e.g. E-SW-BASIC/PQ)

WARNING: drivers USB port is not isolated!

The use of isolator adapter is highly recommended for PC protection (see table GS500)

USB connection

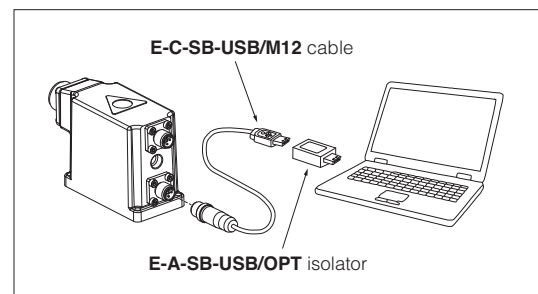

13 ELECTRONIC CONNECTIONS

13.1 Main connector signals - 7 pin - standard and /Q options - AEB and AES (A1)

PIN	Standard	/Q	TECHNICAL SPECIFICATIONS	NOTES
A	V+		Power supply 24 Vdc Rectified and filtered: $V_{RMS} = 20 \div 32 V_{MAX}$ (ripple max 10 % V_{PP})	Input - power supply
B	V0		Power supply 0 Vdc	Gnd - power supply
C	AGND		Analog ground	Gnd - analog signal
		ENABLE	Enable (24 Vdc) or disable (0 Vdc) the driver, referred to V0	Input - on/off signal
D	INPUT+		Reference input signal: $\pm 10 V_{dc}$ / ± 20 mA maximum range Defaults are 0 \div +10 Vdc for standard and 4 \div 20 mA for /I option	Input - analog signal Software selectable
E	INPUT-		Negative reference input signal for INPUT+	Input - analog signal
F	MONITOR referred to: AGND V0		Monitor output signal: $\pm 5 V_{dc}$ maximum range Default is 0 \div +5 Vdc (1V = 1A)	Output - analog signal Software selectable
G	EARTH		Internally connected to driver housing	

13.2 Main connector signals - 12 pin - /Z and /W options - AEB and AES (A2)

PIN	/Z	/W	TECHNICAL SPECIFICATIONS	NOTES
1	V+		Power supply 24 Vdc Rectified and filtered: $V_{RMS} = 20 \div 32 V_{MAX}$ (ripple max 10 % V_{PP})	Input - power supply
2	V0		Power supply 0 Vdc	Gnd - power supply
3	ENABLE		Enable (24 Vdc) or disable (0 Vdc) the driver, referred to V0	Input - on/off signal
4	INPUT+		Reference input signal: $\pm 10 V_{dc}$ / ± 20 mA maximum range Defaults are 0 \div +10 Vdc for standard and 4 \div 20 mA for /I option	Input - analog signal Software selectable
5	INPUT-		Negative reference input signal for INPUT+	Input - analog signal
6	MONITOR		Monitor output signal: $\pm 5 V_{dc}$ maximum range, referred to V0 Default is 0 \div +5 Vdc (1V = 1A)	Output - analog signal
7	NC		Do not connect	
8	NC		Do not connect	
		MONITOR2	2nd monitor output signal: $\pm 5 V_{dc}$ maximum range, default is 0 \div 5 Vdc	Output - analog signal
9	VL+		Power supply 24 Vdc for driver's logic and communication	Input - power supply
10	V0		Power supply 0 Vdc for driver's logic and communication	Gnd - power supply
11	FAULT		Fault (0 Vdc) or normal working (24 Vdc), referred to V0	Output - on/off signal
PE	EARTH		Internally connected to driver housing	

13.3 Communication connectors - AEB (B) and AES (B) - (C)

(B) USB connector - M12 - 5 pin always present		
PIN	SIGNAL	TECHNICAL SPECIFICATION (1)
1	+5V_USB	Power supply
2	ID	Identification
3	GND_USB	Signal zero data line
4	D-	Data line -
5	D+	Data line +

(C1) BC fieldbus execution, connector - M12 - 5 pin (2)		
PIN	SIGNAL	TECHNICAL SPECIFICATION (1)
1	CAN_SHLD	Shield
2	NC	do not connect
3	CAN_GND	Signal zero data line
4	CAN_H	Bus line (high)
5	CAN_L	Bus line (low)

(C2) BP fieldbus execution, connector - M12 - 5 pin (2)		
PIN	SIGNAL	TECHNICAL SPECIFICATION (1)
1	+5V	Termination supply signal
2	LINE-A	Bus line (high)
3	DGND	Data line and termination signal zero
4	LINE-B	Bus line (low)
5	SHIELD	

(C3) (C4) EH fieldbus execution, connector - M12 - 4 pin (2)		
PIN	SIGNAL	TECHNICAL SPECIFICATION (1)
1	TX+	Transmitter
2	RX+	Receiver
3	TX-	Transmitter
4	RX-	Receiver
Housing	SHIELD	

Notes: (1) shield connection on connector's housing is recommended (2) only for AES execution

13.4 Pressure transducer connector - M12 - 5 pin - only for /W option (D)

PIN	SIGNAL	TECHNICAL SPECIFICATION	Voltage	Current
1	VF +24V	Power supply +24Vdc	Connect	Connect
2	TR	Signal transducer maximum range $\pm 10 V_{dc}$ / ± 20 mA, software selectable Defaults are 0 \div 10 Vdc for standard and 4 \div 20 mA for /C option	Connect	Connect
3	AGND	Common GND for transducer power and signals	Connect	/
4	NC	Not Connect	/	/
5	NC	Not Connect	/	/

13.5 Solenoid connection - only for A

PIN	SIGNAL	TECHNICAL SPECIFICATION	Connector code 666
1	COIL	Power supply	
2	COIL	Power supply	
3	GND	Ground	

13.6 Connections layout - only for AEB and AES

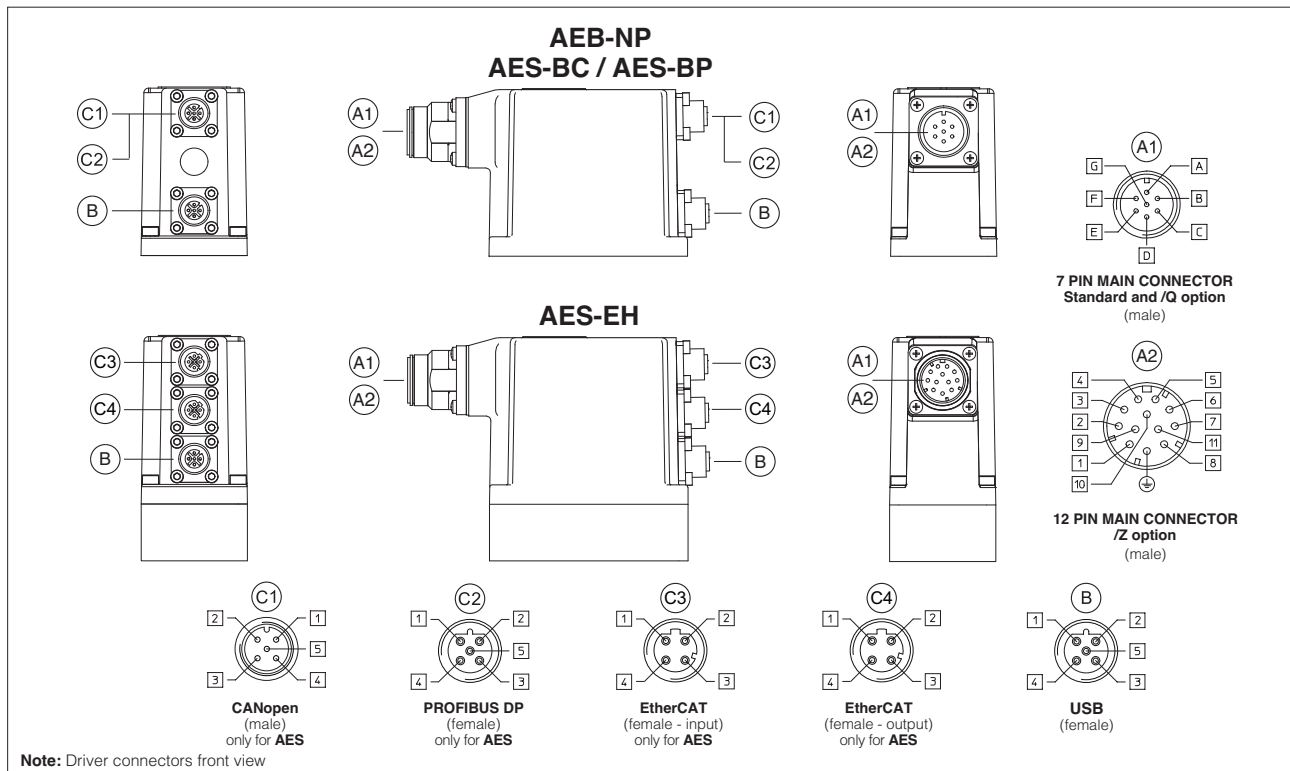

14 CONNECTORS

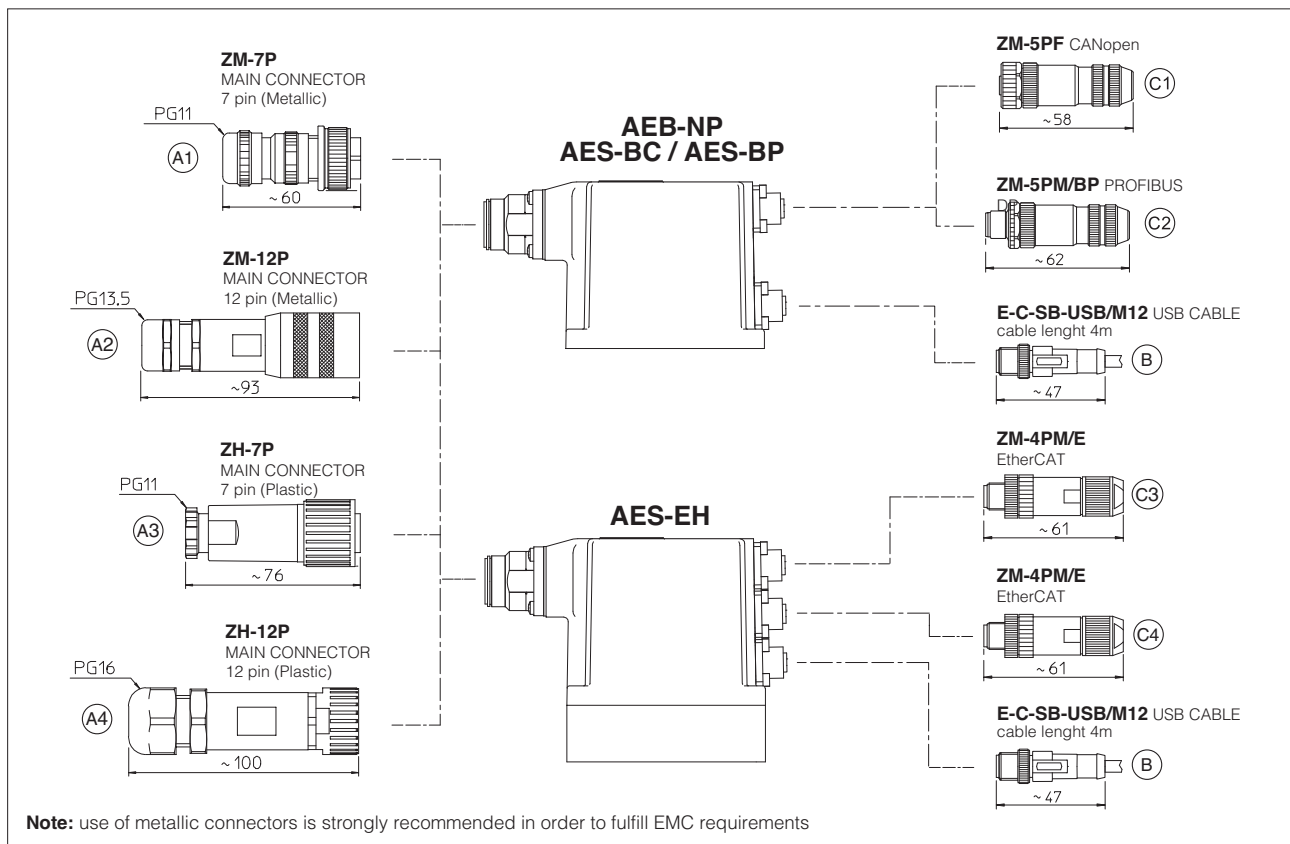

15 MODEL CODES OF MAIN CONNECTORS AND COMMUNICATION CONNECTORS - to be ordered separately

VALVE VERSION	A (1) Power supply	AEB AES	AEB/Z AES/Z	BC - CANopen	BP - PROFIBUS DP	EH - EtherCAT
CONNECTOR CODE	666	ZM-7P (A1)	ZM-12P (A2)	ZM-5PF (C1)	ZM-5PM/BP (C2)	ZM-4PM/E (C3)
		ZH-7P (A3)	ZH-12P (A4)			ZM-4PM/E (C4)
PROTECTION DEGREE	IP67	IP67				
DATA SHEET	K500	GS115, K500				

(1) Connectors supplied with the valve

only for AES

QVHZO

ISO 4401: 2005

Mounting surface: 4401-03-02-0-05 (see tab. P005)

Fastening bolts: 4 socket head screws M5x50 class 12.9

Tightening torque = 8 Nm

Seals: 4 OR 108;

Diameter of ports A, B, P, T: Ø 7,5 mm (max)

① = Space to remove the 7 or 12 pin main connector. For main and communication connectors see section 14, 15

QVHZO-A

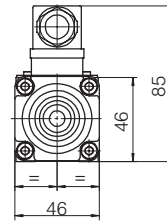
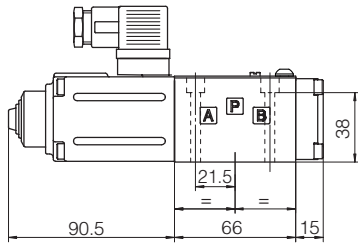

Mass: 2,3 kg

QVHZO-AEB-NP

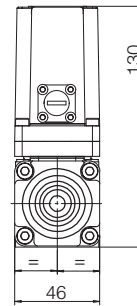
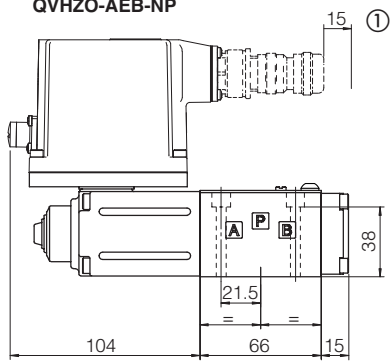

Mass: 2,8 kg

QVHZO-AES-BC QVHZO-AES-BP

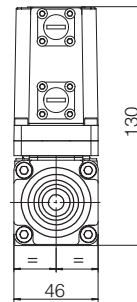
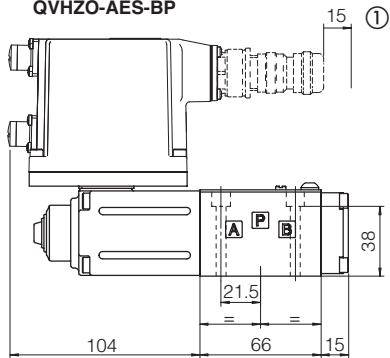

Mass: 2,8 kg

QVHZO-AES-EH

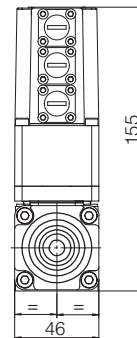
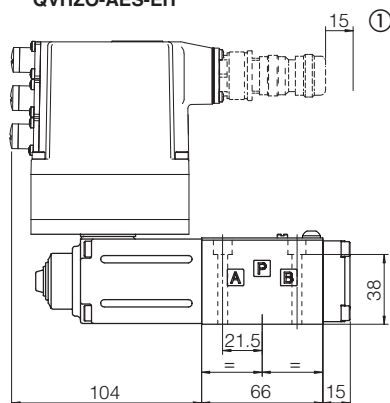

Mass: 2,9 kg

QVKZOR

ISO 4401: 2005

Mounting surface: 4401-05-04-0-05 (see tab. P005)

Fastening bolts: 4 socket head screws M6x40 class 12.9

Tightening torque = 15 Nm

Seals: 5 OR 2050;

Diameter of ports A, B, P, T: \varnothing 11,2 mm (max)

① = Space to remove the 7 or 12 pin main connector. For main and communication connectors see section 14, 15

QVKZOR-A

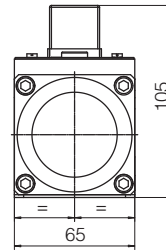
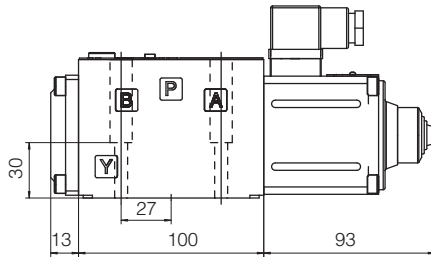

Mass: 3,8 kg

QVKZOR-AEB-NP

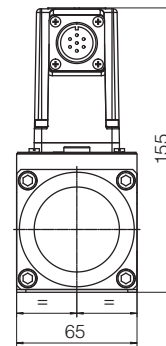
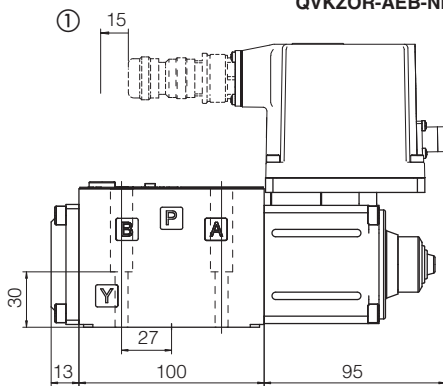

Mass: 4,3 kg

QVKZOR-AES-BC QVKZOR-AES-BP

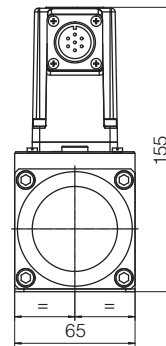
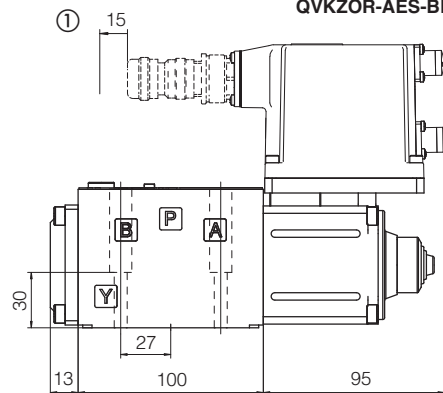

Mass: 4,3 kg

QVKZOR-AES-EH

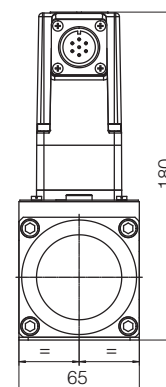
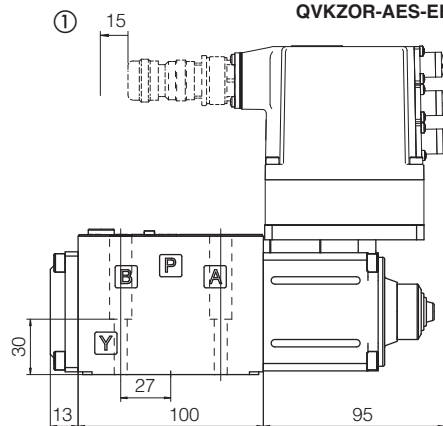

Mass: 4,4 kg