

Proportional pressure reducing valves type **DHRZO**

direct operated, ISO 4401 size 06

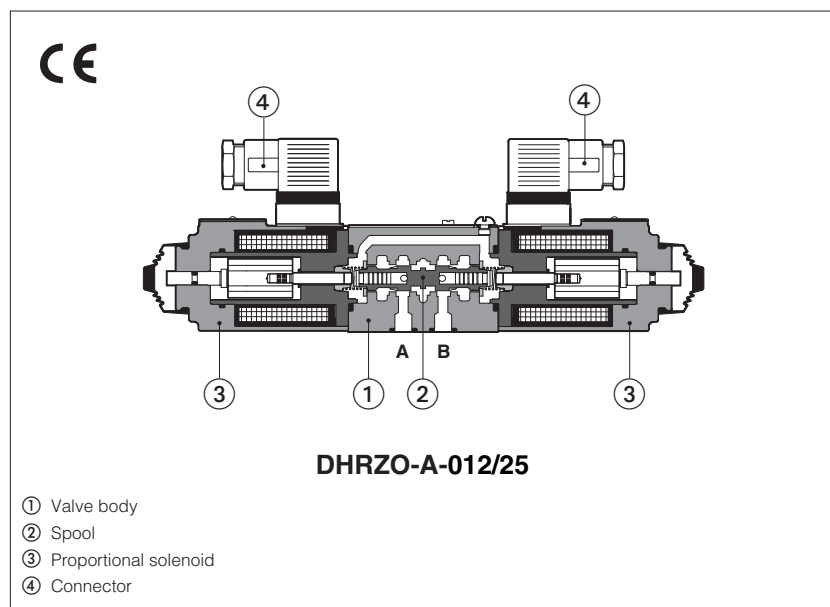

DHRZO are 3 way, proportional pressure reducing valves, direct operated, with standard ISO 4401 size 06 mounting surface

Technical characteristics

They provide the pressure reduction on ports A, or B or A and B, depending on the valve model. The direct execution performs low internal leakages, fast response and low hysteresis.

The valves are available in different executions: proportional solenoids with separated (-A) or integral (-AEB/-AES) digital electronics

Typical applications

Pressure reduction in low flow systems
Pilot stage for proportional valves DPZO-A*

Mounting surface: ISO 4401, size 06
Max flow: 24 l/min
Max pressure: 315 bar
Max regulated pressure: 25 bar

- ① Valve body
- ② Spool
- ③ Proportional solenoid
- ④ Connector

1 MODEL CODE

DHRZO	-	A	-	EB	-	NP	-	010	/	25	/	*	/	**	/	*
<p>Proportional pressure reducing valve size 06</p> <p>A = open loop pressure control</p> <p>- = omit for execution with separated driver see section 8</p> <p>EB = basic integral driver ES = full integral driver</p> <p>Fieldbus interfaces - USB port always present (1): NP = Not present BP = PROFIBUS DP BC = CANopen EH = EtherCAT</p> <p>Configuration: 010 = reduced pressure on port A 012 = reduced pressure on port A and B</p>													<p>Seals material, see sect. 5, 6: - = NBR PE = FKM BT = HNBR</p> <p>Series number</p>			
<p>B = reduced port B (only for configuration 010); Coil voltage only for -A - see section 8: - = standard coil for 24V_{DC} Atos drivers 6 = optional coil for 12V_{DC} Atos drivers 18 = optional coil for low current drivers</p> <p>Electronics options only for AEB and AES - see section 9: I = current reference input 4 ÷ 20 mA (omit for standard voltage reference input 0 ÷ 10 V) Q = enable signal Z = double power supply, enable, fault and monitor signals - 12 pin connector</p>													<p>Regulated pressure: 25 = reduced pressure range 3÷25 bar</p>			

(1) Omit for **A** execution; **AEB** available only in version **NP**; **AES** available only in version **BC, BP, EH**

2 ELECTRONIC DRIVERS

Valve model	A										AEB	AES
	E-MI-AC-01F		E-BM-AC-01F		E-ME-AC-01F	E-MI-AS-IR		E-BM-AS-PS		E-BM-AES	E-RI-AEB	E-RI-AES
Type	Analog					Digital						
Voltage supply (V _{DC})	12	24	12	24	24	12	24	12	24	24	24	
Valve coil option	/6	std	/6	std	std	/6	std	/6	std	std	std	
Format	plug-in to solenoid		DIN 43700 UNDECAL		EUROCARD	plug-in to solenoid		DIN-rail panel			Integral to valve	
Data sheet	G010		G025		G035	G020		G030	GS050		GS115	

Note: for main and communication connector see sections 11, 12

Hydraulic symbol

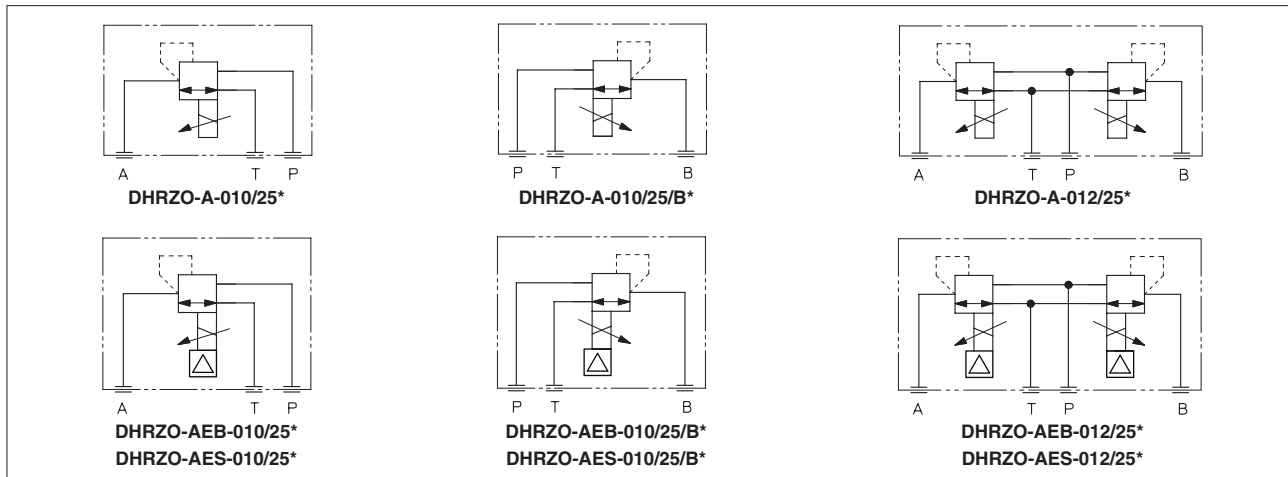

3 GENERAL NOTES

DHRZO-A* proportional valves are CE marked according to the applicable Directives (e.g. Immunity/Emission EMC Directive and Low Voltage Directive).

Installation, wirings and start-up procedures must be performed according to the general prescriptions shown in table F003 and in the installation notes supplied with relevant components.

4 FIELDBUS - only for AES

Fieldbus allows the direct communication of the proportional valve with machine control unit for digital reference signal, diagnostics and settings of functional parameters. Analog reference signal remain available on the main connector for quick commissioning and maintenance. For detailed information about fieldbus features and specification see tech table **GS510**.

5 MAIN CHARACTERISTICS - based on mineral oil ISO VG 46 at 50 °C

Assembly position	Any position			
Subplate surface finishing	Roughness index, Ra 0,4 flatness ratio 0,01/100 (ISO 1101)			
MTTFd valves according to EN ISO 13849	150 years, see technical table P007			
Ambient temperature range	A: standard = -20°C ÷ +70°C,		/BT option = -40°C ÷ +60°C	
	AEB, AES: standard = -20°C ÷ +60°C,		/BT option = -40°C ÷ +60°C	
Storage temperature range	A: standard = -20°C ÷ +80°C,		/BT option = -40°C ÷ +70°C	
	AEB, AES: standard = -20°C ÷ +70°C,		/BT option = -40°C ÷ +70°C	
Coil resistance R at 20°C	Standard = 3 ÷ 3,3 Ω	Option /6 = 2 ÷ 2,2 Ω	Option /18 = 13 ÷ 13,4 Ω	
Max. solenoid current	Standard = 2,4A (1,8 for /32)	Option /6 = 3A (2,25A for /32)	Option /18 = 1A (0,8A for /32)	
Max. power	A = 30 Watt AEB, AES = 50 Watt			
Insulation class	H (180°) Due to the occurring surface temperatures of the solenoid coils, the European standards ISO 13732-1 and EN982 must be taken into account			
Protection degree to DIN EN60529	IP66/67 with mating connectors			
Tropicalization (only AEB, AES)	Tropical coating on electronics PCB			
Duty factor	Continuous rating (ED=100%)			
EMC, climate and mechanical load	See technical table G004			
Communication interface (only AEB, AES)	USB Atos ASCII coding	CANopen EN50325-4 + DS408	PROFIBUS DP EN50170-2/IEC61158	EtherCAT IEC 61158
Communication physical layer (only AEB, AES)	not insulated USB 2.0 + USB OTG	optical insulated CAN ISO11898	optical insulated RS485	Fast Ethernet, insulated 100 Base TX
Max regulated pressure (Q=1 l/min) [bar]	25			
Min. regulated pressure (Q=1 l/min) (1) [bar]	3			
Max. pressure at port P [bar]	315			
Max. pressure at port T [bar]	210			
Max. flow [l/min]	24			
Response time 0-100% step signal (2) (depending on installation) [ms]	≤ 45			
Hysteresis [% of the max pressure]	≤ 1,5			
Linearity [% of the max pressure]	≤ 3			
Repeatability [% of the max pressure]	≤ 2			

Notes: above performance data refer to valves coupled with Atos electronic drivers, see section 2

(1) Min pressure value to be increased of T line pressure

(2) Average response time value; the pressure variation in consequence of a modification of the reference input signal to the valve is affected by the stiffness of the hydraulic circuit: greater is the stiffness of the circuit, faster is the dynamic response

6 SEALS AND HYDRAULIC FLUID - for other fluids not included in below table, consult our technical office

Seals, recommended fluid temperature	NBR seals (standard) = -20°C ÷ +60°C, with HFC hydraulic fluids = -20°C ÷ +50°C FKM seals (/PE option) = -20°C ÷ +80°C HNBR seals (/BT option) = -40°C ÷ +60°C, with HFC hydraulic fluids = -40°C ÷ +50°C		
Recommended viscosity	20÷100 mm ² /s - max allowed range 15 ÷ 380 mm ² /s		
Fluid contamination class	ISO 4406 class 20/18/15 NAS 1638 class 9, in line filters of 10 µm (β10 ≥75 recommended)		
Hydraulic fluid	Suitable seals type	Classification	Ref. Standard
Mineral oils	NBR, FKM, HNBR	HL, HLP, HLPD, HVLP, HVLPD	DIN 51524
Flame resistant without water	FKM	HFDU, HFDR	ISO 12922
Flame resistant with water	NBR, HNBR	HFC	

7 DIAGRAMS based on mineral oil ISO VG 46 at 50°C

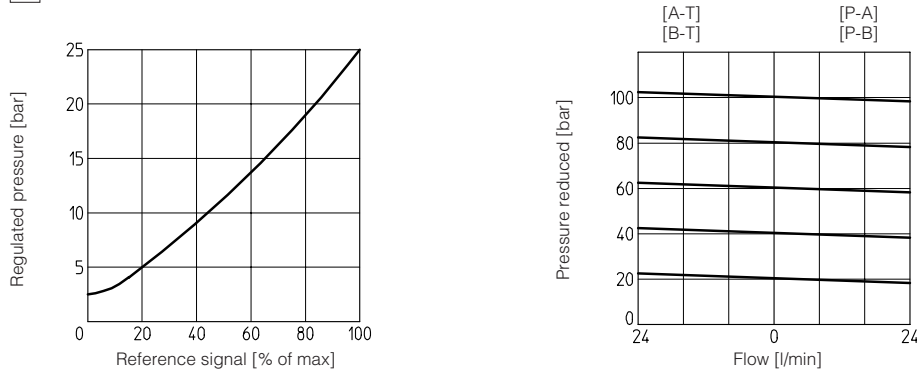

8 OPTIONS for -A

8.1 Coil voltage

Option /6 optional coil to be used with Atos drivers with power supply 12 Vdc

Option /18 optional coil to be used with electronic drivers not supplied by Atos

9 ELECTRONIC OPTIONS - for AEB and AES

Standard driver execution provides on the 7 pin main connector:

Power supply - 24Vdc must be appropriately stabilized or rectified and filtered; a 2,5 A fuse time lag is required in series to each driver power supply. Apply at least a 10000 µF/40 V capacitance to single phase rectifiers or a 4700 µF/40 V capacitance to three phase rectifiers

Reference input signal - analog differential input with 0÷+10 Vdc nominal range (pin D,E), proportional to desired valve pressure regulation

Monitor output signal - analog output signal proportional to the actual valve's coil current (1V monitor = 1A coil current)

Note: a minimum booting time of 500 ms has been considered from the driver energizing with the 24 Vdc power supply before the valve has been ready to operate. During this time the current to the valve coils is switched to zero.

9.1 Option /I

It provides 4 ÷ 20 mA current reference signal, instead of the standard 0÷+10 Vdc.

Input signal can be reconfigured via software selecting between voltage and current, within a maximum range of ±10 V or ±20 mA.

It is normally used in case of long distance between the machine control unit and the valve or where the reference signal can be affected by electrical noise; the valve functioning is disabled in case of reference signal cable breakage

9.2 Option /Q

To enable the driver, supply 24 Vdc on pin C referred to pin B: Enable input signal allows to enable/disable the current supply to the solenoid, without removing the electrical power supply to the driver; it is used to maintain active the communication and the other driver functions when the valve has to be disabled. This condition does not comply with European Norms EN13849-1 (ex EN954-1).

9.3 Option /Z

It provides, on the 12 pin main connector, the following additional features:

Enable Input Signal

To enable the driver, supply 24 Vdc on pin 3 referred to pin 2: Enable input signal allows to enable/disable the current supply to the solenoid, without removing the electrical power supply to the driver; it is used to maintain active the communication and the other driver functions when the valve has to be disabled. This condition does not comply with European Norms EN13849-1 (ex EN954-1).

Fault Output Signal

Fault output signal indicates fault conditions of the driver (solenoid short circuits/not connected, reference signal cable broken for 4÷20mA input, etc.). Fault presence corresponds to 0 Vdc, normal working corresponds to 24 Vdc (pin 11 referred to pin 2): Fault status is not affected by the Enable input signal

Power supply for driver's logics and communication

Separate power supply (pin 9,10) allow to cut solenoid power supply (pin 1,2) while maintaining active diagnostics, serial and fieldbus communication. A safety fuse is required in series to each driver power supply: 500 mA fast fuse

9.4 Possible combined options: /I,Q, /I,Z

10 ELECTRONIC CONNECTIONS

10.1 Main connector signals - 7 pin - standard and /Q option - DHRZO-AEB and DHRZO-AES (A1)

PIN	Standard	/Q	TECHNICAL SPECIFICATIONS	NOTES
A	V+		Power supply 24 Vdc Rectified and filtered: $V_{RMS} = 20 \div 32 V_{MAX}$ (ripple max 10 % V_{PP})	Input - power supply
B	V0		Power supply 0 Vdc	Gnd - power supply
C	AGND		Analog ground	Gnd - analog signal
		ENABLE	Enable (24 Vdc) or disable (0 Vdc) the driver, referred to V0	Input - on/off signal
D	INPUT+		Pressure reference input signal: $\pm 10 Vdc / \pm 20 mA$ maximum range Defaults are $0 \div 10 Vdc$ for standard and $4 \div 20 mA$ for /I option	Input - analog signal Software selectable
E	INPUT-		Negative reference input signal for P_INPUT+	Input - analog signal
F	MONITOR referred to: AGND V0		Pressure monitor output signal: $\pm 5 Vdc$ maximum range Default is $0 \div 5 Vdc$ ($1V = 1A$)	Output - analog signal Software selectable
G	EARTH		Internally connected to driver housing	

10.2 Main connector signals - 12 pin - /Z option - DHRZO-AEB and DHRZO-AES (A2)

PIN	/Z	TECHNICAL SPECIFICATIONS	NOTES
1	V+	Power supply 24 Vdc Rectified and filtered: $V_{RMS} = 20 \div 32 V_{MAX}$ (ripple max 10 % V_{PP})	Input - power supply
2	V0	Power supply 0 Vdc	Gnd - power supply
3	ENABLE	Enable (24 Vdc) or disable (0 Vdc) the driver, referred to V0	Input - on/off signal
4	INPUT+	Pressure reference input signal: $\pm 10 Vdc / \pm 20 mA$ maximum range Defaults are $0 \div 10 Vdc$ for standard and $4 \div 20 mA$ for /I option	Input - analog signal Software selectable
5	INPUT-	Negative reference input signal for P_INPUT+	Input - analog signal
6	MONITOR	Pressure monitor output signal: $\pm 5 Vdc$ maximum range Defaults is $0 \div 5 Vdc$ ($1V = 1A$)	Output - analog signal Software selectable
7	NC	Do not connect	
8	NC	Do not connect	
9	VL+	Power supply 24 Vdc for driver's logic and communication	Input - power supply
10	VLO	Power supply 0 Vdc for driver's logic and communication	Gnd - power supply
11	FAULT	Fault (0 Vdc) or normal working (24 Vdc), referred to V0	Output - on/off signal
PE	EARTH	Internally connected to driver housing	

10.3 Communication connectors - DHRZO-AEB (B) and DHRZO-AES (B) (C)

(B) USB connector - M12 - 5 pin always present		
PIN	SIGNAL	TECHNICAL SPECIFICATION (1)
1	+5V_USB	Power supply
2	ID	Identification
3	GND_USB	Signal zero data line
4	D-	Data line -
5	D+	Data line +

(C1) BC fieldbus execution, connector - M12 - 5 pin (2)		
PIN	SIGNAL	TECHNICAL SPECIFICATION (1)
1	CAN_SHLD	Shield
2	NC	do not connect
3	CAN_GND	Signal zero data line
4	CAN_H	Bus line (high)
5	CAN_L	Bus line (low)

(C2) BP fieldbus execution, connector - M12 - 5 pin (2)		
PIN	SIGNAL	TECHNICAL SPECIFICATION (1)
1	+5V	Termination supply signal
2	LINE-A	Bus line (high)
3	DGND	Data line and termination signal zero
4	LINE-B	Bus line (low)
5	SHIELD	

(C3) (C4) EH fieldbus execution, connector - M12 - 4 pin (2)		
PIN	SIGNAL	TECHNICAL SPECIFICATION (1)
1	TX+	Transmitter
2	RX+	Receiver
3	TX-	Transmitter
4	RX-	Receiver
Housing	SHIELD	

Notes: (1) shield connection on connector's housing is recommended (2) only for AES execution

10.4 Solenoid connection - only for RZGO-A

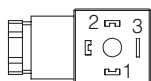
PIN	SIGNAL	TECHNICAL SPECIFICATION	Connector code 666 
1	COIL	Power supply	
2	COIL	Power supply	
3	GND	Ground	

10.5 Connections layout - only for AEB and AES

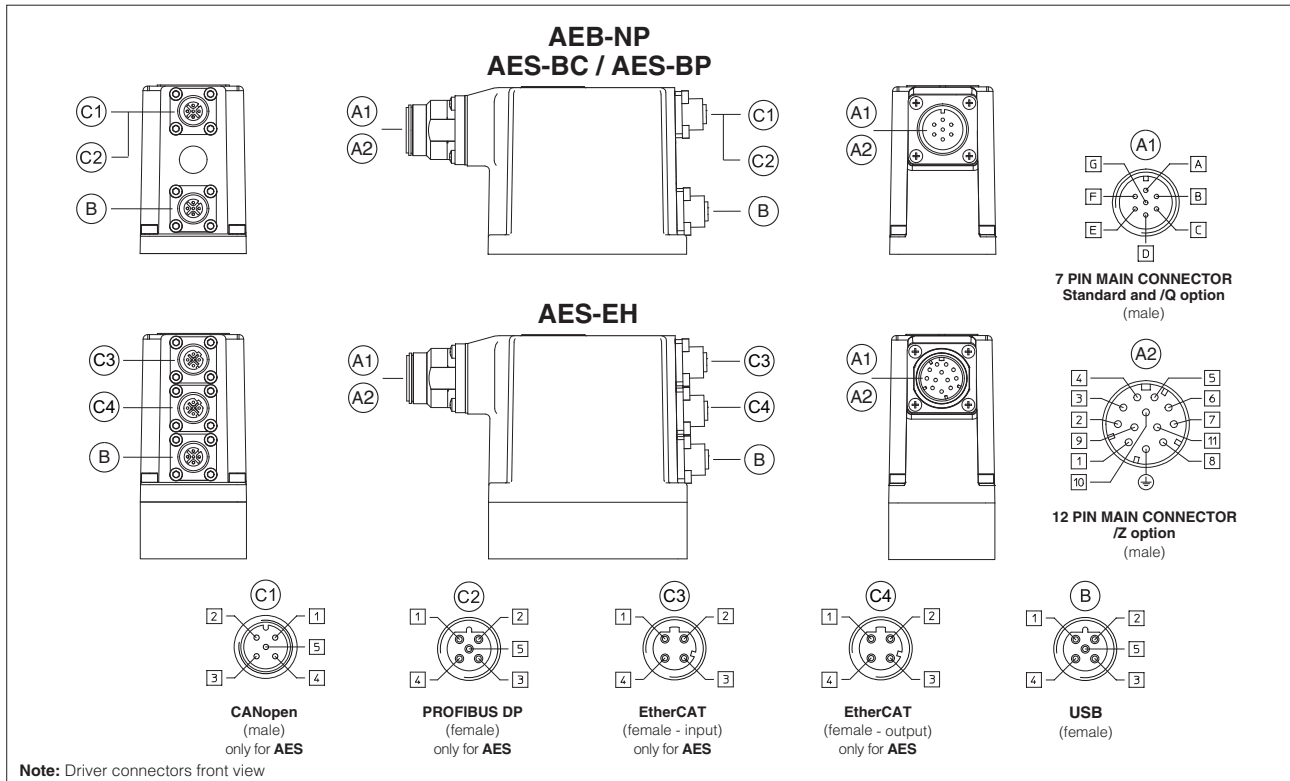

11 CONNECTORS

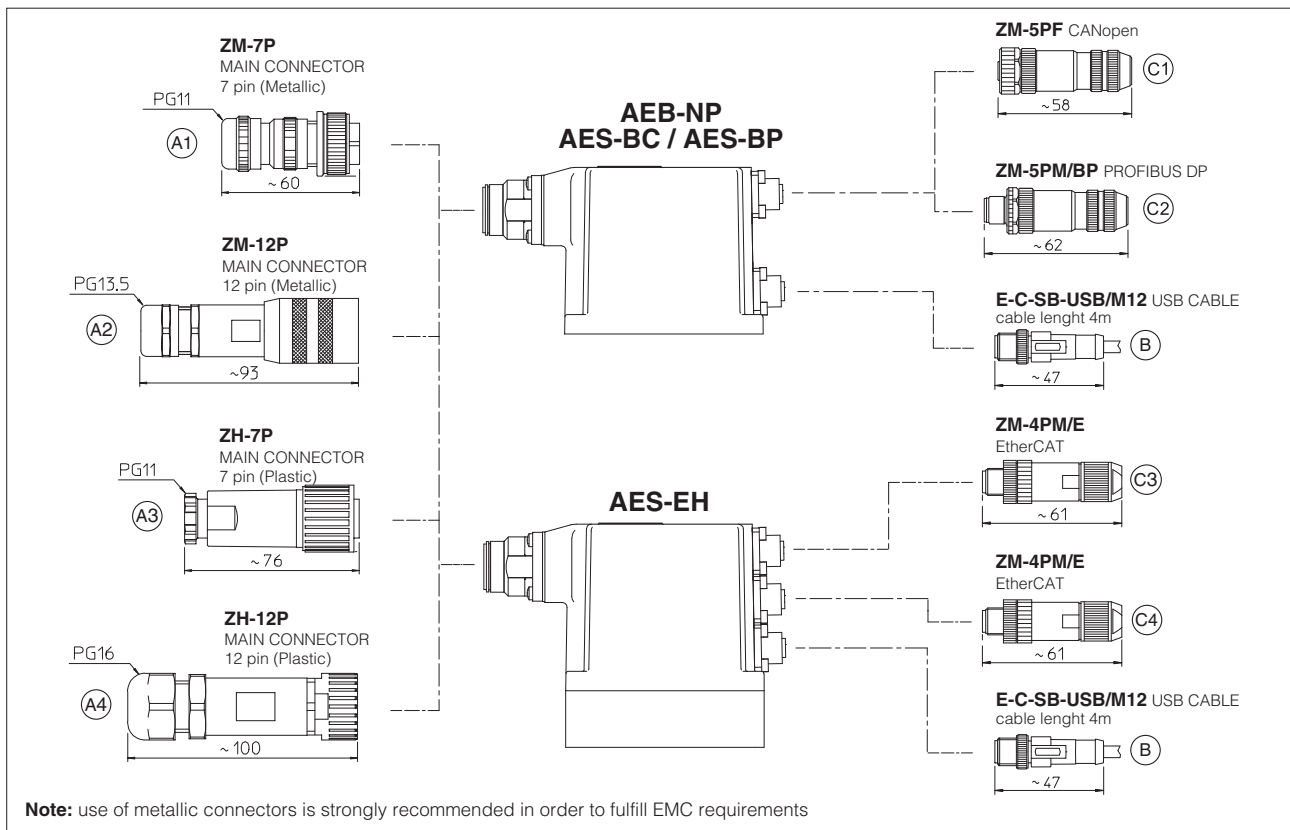

12 MODEL CODES OF MAIN CONNECTORS AND COMMUNICATION CONNECTORS - to be ordered separately

VALVE VERSION	A (1) Power supply	AEB AES	AEB/Z AES/Z	BC - CANopen	BP - PROFIBUS DP	EH - EtherCAT
CONNECTOR CODE	666	ZM-7P (A1)	ZM-12P (A2)	ZM-5PF (C1)	ZM-5PM/BP (C2)	ZM-4PM/E (C3)
		ZH-7P (A3)	ZH-12P (A4)			ZM-4PM/E (C4)
PROTECTION DEGREE	IP67	IP67				
DATA SHEET	K500	GS115, K500				

(1) Connectors supplied with the valve

only for AES

13 INSTALLATION DIMENSIONS FOR DHRZO [mm]

ISO 4401: 2005

Mounting surface: 4401-03-02-0-05 (see table P005)

Fastening bolts: 4 socket head screws M5x50 class 12.9

Tightening torque = 8 Nm

Seals: 4 OR 108; 1 OR 2025

Diameter of ports A, B, P, T: \varnothing 7,5 mm (max)

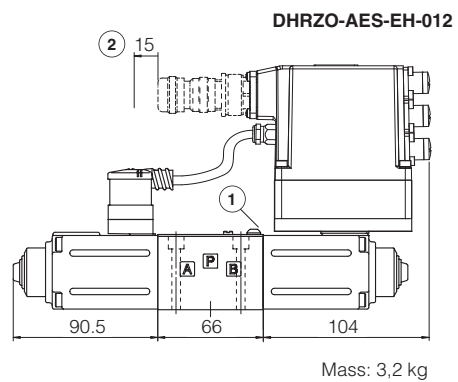
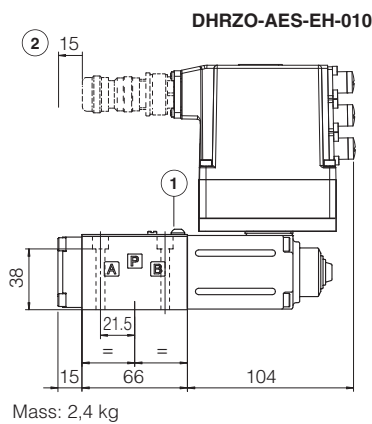
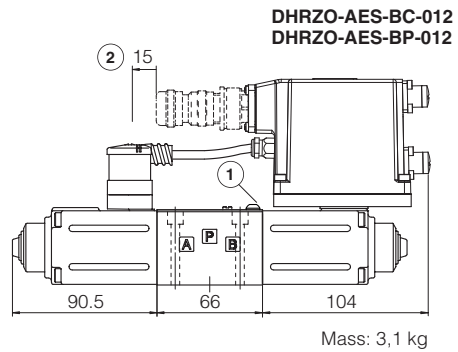
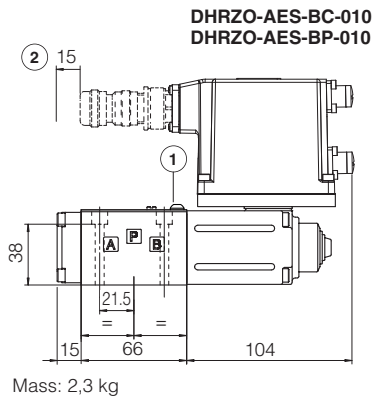
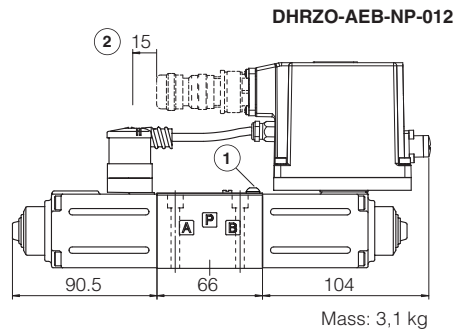
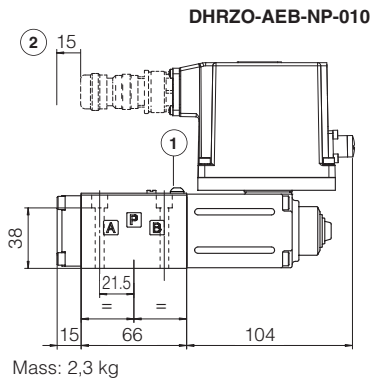
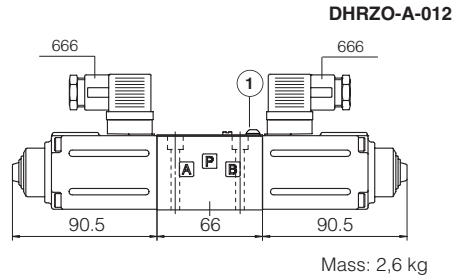
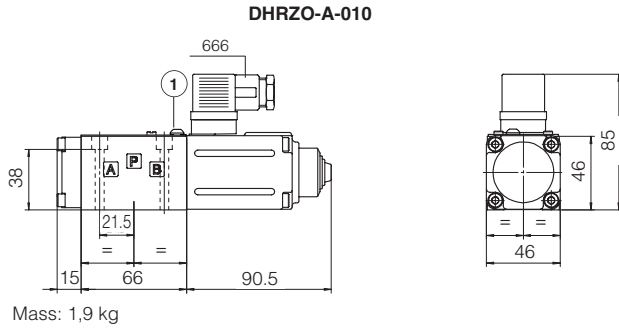

① = Screw for air bleeding: at the first valve commissioning the air eventually trapped inside the solenoid must be bled-off through the screw ①

② = Space to remove the 7 or 12 pin main connector. For main and communication connectors see section 11, 12