

Proportional directional valves

pilot operated, open loop

Available only on request

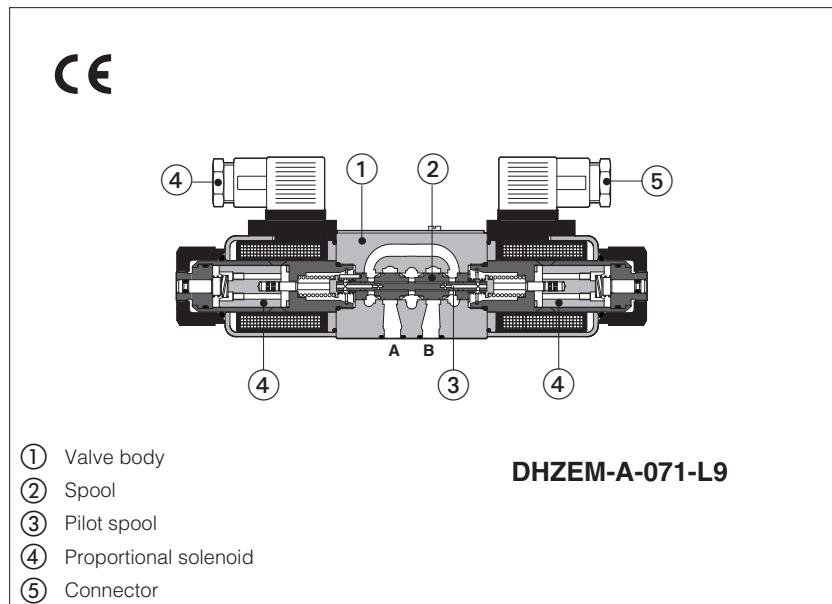

DHZEM-A

Open-loop, pilot operated proportional directional valves size 06, characterized by high flow capability up to 140 l/min and compact dimensions.

They are the ideal solution for applications with limited space, where the high flow performances are required for a short period, then the valve dimensions are privileged respect to the pressure drops.

They operate in association with electronic drivers, selectable with different format and performances, see section 2

The spools are available with linear **L**, flow characteristics.

The solenoid's coils are available for voltage supply 12 VDC or 24 VDC and with optional mobile connectors.

Size: **06**

Max flow: up to **140**

Max pressure: **350 bar**

1 MODEL CODE

DHZE - **M** - **A** - **0** - **71** - **L** - **9** - ***** / ***** - ****** / *****

DHZE = size 06

M = high flow execution

A = open loop

Valve size - ISO 4401

0 = size 06

Configuration:

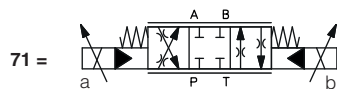

Spool type - regulating characteristics:

L = linear



Seals material, see section 4:

- = NBR
- PE** = FKM
- BT** = HNBR

Series number

Coil option

see section 2 and 3:

- = standard coil for 24V_{DC} Atos drivers

6 = optional coil for 12V_{DC} Atos drivers

18 = optional coil for 24V_{DC} low current drivers

Coils with special connectors, see section 8

- = omit for standard DIN connector

J = AMP Junior Timer connector

K = Deutsch connector

S = Lead Wire connection

Spool size: **9** = 50 (l/min) at Δp 30 bar P-T

Max flow 140 l/min at Δp 240 bar P-T

2 ELECTRONIC DRIVERS

Drivers model	E-MI-AC		E-MI-AS-IR		E-BM-AC		E-BM-AS-PS		E-BM-AES	E-ME-AC
Type	analog		digital		analog		digital		digital	analog
Voltage supply (V_{DC})	12	24	12	24	12	24	12	24	24	24
Valve coil option	/6	std	/6	std	/6	std	/6	std	std	std
Format	DIN 43650 plug-in to solenoid				DIN 43700 UNDECAL		DIN-rail panel			EUROCARD
Data sheet	G010		G020		G025		G030		GS050	G035

3 MAIN CHARACTERISTICS - based on mineral oil ISO VG 46 at 50 °C

Assembly position	Any position
Subplate surface finishing	Roughness index, Ra 0,4 flatness ratio 0,01/100 (ISO 1101)
MTTFd valves according to EN ISO 13849	150 years, see technical table P007
Ambient temperature range	standard = -20°C ÷ +70°C, /BT option = -40°C ÷ +60°C
Storage temperature range	standard = -20°C ÷ +80°C, /BT option = -40°C ÷ +70°C
Coil code	standard option /6 option /18
Coil resistance R at 20°C	3 ÷ 3,3 Ω 2 ÷ 2,2 Ω 13 ÷ 13,4 Ω
Max. solenoid current	2,2 A 2,75 A 1 A
Max. power	30W
Insulation class	H (180°) Due to the occurring surface temperatures of the solenoid coils, the European standards ISO 13732-1 and EN982 must be taken into account
Protection degree to DIN EN60529	IP67
Duty factor	Continuous rating (ED=100%)
Certification	cURus North American Standard

Valve model	DHZEM	
Pressure limits [bar]	ports P, A, B = 350; T = 210	
Spool type and size	L9	
Nominal flow (1) [l/min]		
at $\Delta p = 10$ bar (P-T)	28	
at $\Delta p = 30$ bar (P-T)	50	
at $\Delta p = 70$ bar (P-T)	80	
at $\Delta p_{max} = 240$ bar (P-T)	140	
Response time (2) [ms]	< 30	
Hysteresis [%]	5 [% of max regulation]	
Repeatability [%]	± 1 [% of max regulation]	

Notes: above performance data refer to valves coupled with Atos electronic drivers, see section 2.
the flow regulated by the directional proportional valves is not pressure compensated, thus it is affected by the load variations. To keep constant the regulated flow under different load conditions, modular pressure compensators are available (see tab. D150).

(1) For different Δp , the max flow is in accordance to the diagrams in section 7

(2) 0-100% step signal

4 SEALS AND HYDRAULIC FLUID - for other fluids not included in below table, consult our technical office

Seals, recommended fluid temperature	NBR seals (standard) = -20°C ÷ +60°C, with HFC hydraulic fluids = -20°C ÷ +50°C FKM seals (/PE option) = -20°C ÷ +80°C HNBR seals (/BT option) = -40°C ÷ +60°C, with HFC hydraulic fluids = -40°C ÷ +50°C		
Recommended viscosity	20 ÷ 100 mm ² /s - max allowed range 15 ÷ 380 mm ² /s		
Fluid contamination class	ISO 4406 class 20/18/15 NAS 1638 class 9, in line filters of 10 µm ($\beta_{10} \geq 75$ recommended)		
Hydraulic fluid	Suitable seals type	Classification	Ref. Standard
Mineral oils	NBR, FKM, HNBR	HL, HLP, HLPD, HVLP, HVLDP	DIN 51524
Flame resistant without water	FKM	HFDU, HFDR	ISO 12922
Flame resistant with water	NBR, HNBR	HFC	

5 GENERAL NOTES

DHZEM proportional valves are CE marked according to the applicable Directives (e.g. Immunity/Emission EMC Directive and Low Voltage Directive).

Installation, wirings and start-up procedures must be performed according to the general prescriptions shown in table F003 and in the installation notes supplied with relevant components.

6 CONNECTIONS

SOLENOID POWER SUPPLY CONNECTOR		
PIN	Signal description	
1	SUPPLY	
2	SUPPLY	
3	GND	

7 DIAGRAM FOR DHZEM (based on mineral oil ISO VG 46 at 50 °C)

Regulation diagrams

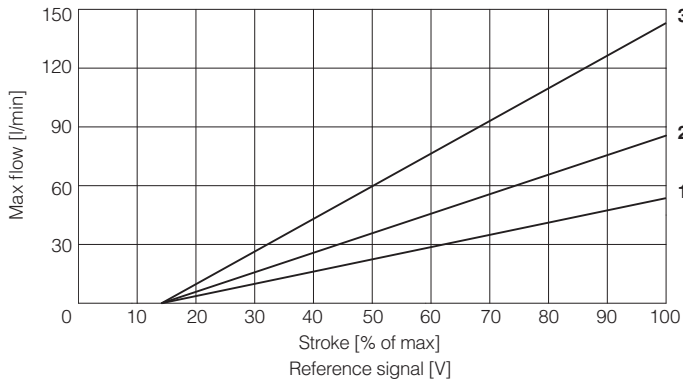

- 1 = linear spool L9 at Δp 30 bar
- 2 = linear spool L9 at Δp 70 bar
- 3 = linear spool L9 at Δp max

8 COILS WITH SPECIAL CONNECTORS

Options -J

Coil type COZEJ
AMP Junior Timer connector
Protection degree IP67

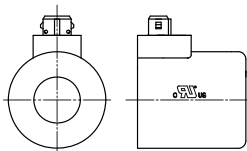

Options -K

Coil type COZEK
Deutsch connector, DT-04-2P male
Protection degree IP67

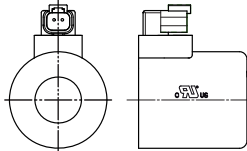

Options -S

Coil type COZES
Lead Wire connection
Cable length = 180 mm

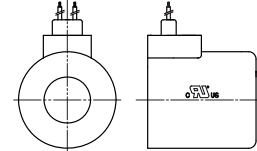

9 INSTALLATION DIMENSIONS FOR DHZEM [mm]

ISO 4401: 2005

Mounting surface: 4401-03-02-0-05 (see table P005)

Fastening bolts: 4 socket head screws M5x30 class 12.9

Tightening torque = 8 Nm

Seals: 4 OR 108

Diameter of ports A, B, P, T: \varnothing 7,5 mm (max)

DHZEM-A-07

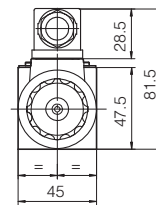
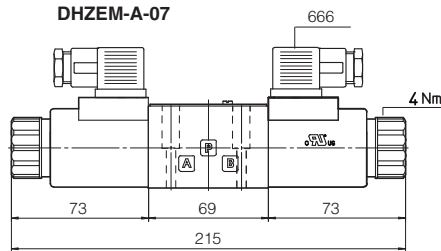

Mass: 2 kg

DHZEM-A-07
(with digital driver
E-MI-AS-IR)

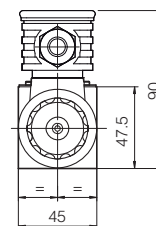
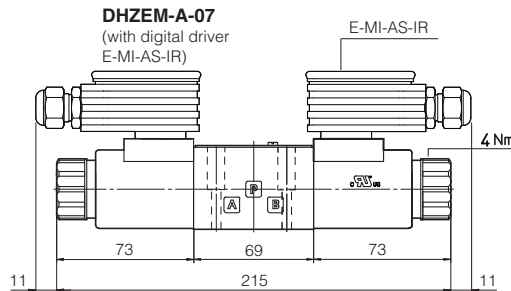

Mass: 3 kg