

Proportional 2-way cartridges

rugged digital, with position transducers, ISO 7368 sizes from 16 to 80

Available only on request

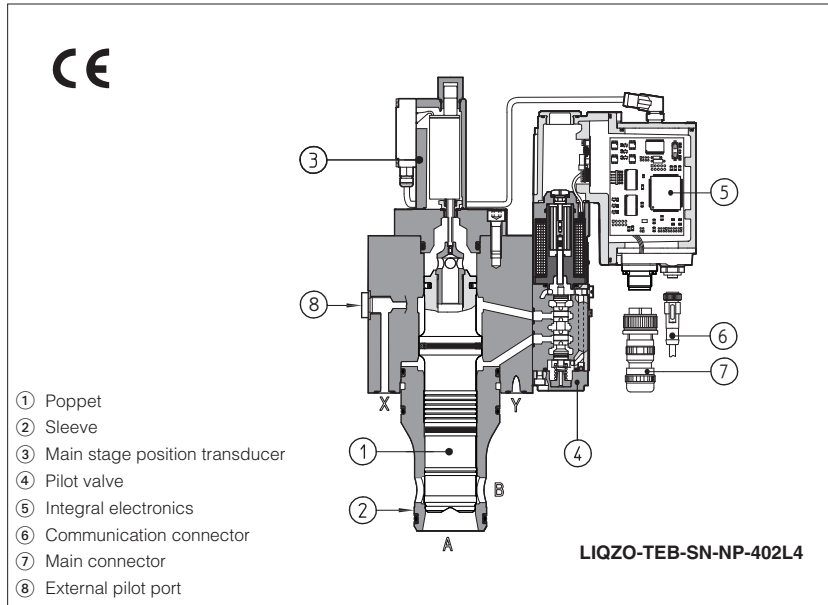

LIQZO-TEB and LIQZP-TEB

2-way proportional cartridge valves specifically designed for throttling functions and not compensated flow regulations in hydraulic systems.

The valve poppet is controlled in closed loop by means of a LVDT position transducer and a proportional pilot valve type DHZO, see table F160

The cartridge execution for blocks installation grants high flow capabilities and minimized pressure drops.

The integral analog electronic driver performs the valve's hydraulic regulation according to the reference signal and assures valve-to-valve interchangeability thanks to the factory presetting.

TEB basic execution is operated with analog reference signals and it is provided with USB port for software functional parameters setting.

LIQZO: sizes from 16 to 40,
Max flow: 600 to 2500 l/min
Max pressure: 350 bar

LIQZP: sizes from 50 to 80
Max flow: 4000 to 10.000 l/min
Max pressure: 420 bar

1 MODEL CODE

*	LIQZO	-	T	EB	-	SN	-	NP	-	25	2	L4	/	*	**	/	*
<p>speed code</p> <p>- omit for size 16 to 50 104119 only for LIQZP size 63 131114 only for LIQZP size 80</p> <p>Flow control valve</p> <p>LIQZO size 16 to 40, Pmax 350 bar</p> <p>LIQZP size 50 to 80, Pmax 420 bar</p> <p>T = closed-loop - one LVDT transducer</p> <p>Integral digital drivers: EB = basic (1)</p> <p>Alternated P/Q controls SN = none</p> <p>Fieldbus interfaces USB port always present: NP = Not present</p>																	<p>Seals material, see sect. 4): - = NBR PE = FKM</p> <p>Series number</p> <p>Electronic options, see sect. 8)</p> <p>I = current reference input and monitor 4±20 mA (omit for standard voltage reference input and monitor ±10 V)</p> <p>F = fault signal</p> <p>Q = enable signal</p> <p>Z = enable, fault and monitor signals (12 pin connector)</p>
<p>Spool type - regulating characteristics:</p> <p>L4 = linear</p>												<p>Configuration: 2 = 2 way</p>					

Valve size, see section 3)

LIQZO =	16	25	32	40
l/min	250	500	800	1200

LIQZP =	50	63	80
l/min	2000	3000	4500

Nominal flow (l/min) at Δp 5 bar

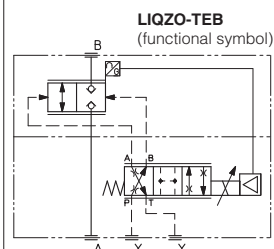

LIQZO-TEB (simplified symbol)

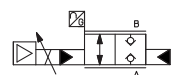

2 GENERAL NOTES

LIQZO-TEB and LIQZP-TEB proportional cartridges are **CE** marked according to the applicable Directives (e.g. Immunity/Emission EMC Directive and Low Voltage Directive). Installation, wirings and start-up procedures must be performed according to the general prescriptions shown in table F003 and in the installation notes supplied with relevant components.

The electrical signals of the valve (e.g. monitor signals) must not be directly used to activate safety functions, like to switch-ON/OFF the machine's safety components, as prescribed by the European standards (Safety requirements of fluid technology systems and components-hydraulics, EN-982).



WARNING

To avoid overheating and possible damage of the electronic driver, the valves must be never energized without hydraulic supply to the pilot stage. In case of prolonged pauses of the valve operation during the machine cycle, it is always advisable to disable the driver (option /Q or /Z)

A safety fuse 2,5 A installed on 24Vdc power supply of each valve is always recommended, see also Power supply note at sections 7



WARNING

The loss of the pilot pressure causes the undefined position of the main spool.

The sudden interruption of the power supply during the valve operation causes the immediate shut-off of the main spool.

This could cause pressure surges in the hydraulic system or high decelerations which may lead to machine damages.

3 MAIN CHARACTERISTICS - based on mineral oil ISO VG 46 at 50 °C

Assembly position	Any position
Subplate surface finishing	Roughness index, Ra 0,4 flatness ratio 0,01/100 (ISO 1101)
MTTFd valves according to EN ISO 13849	75 years, see technical table P007
Ambient temperature range	Standard execution = -20°C ÷ +60°C
Storage temperature range	Standard execution = -20°C ÷ +70°C
Coil resistance R at 20°C	3 ÷ 3,3 Ω
Max. solenoid current	2,6 A
Max. power	50 Watt
Insulation class	H (180°) Due to the occurring surface temperatures of the solenoid coils, the European standards ISO 13732-1 and EN982 must be taken into account
Protection degree to DIN EN60529	IP66/67
Tropicalization	Tropical coating on electronics PCB
Duty factor	Continuous rating (ED=100%)
EMC, climate and mechanical load	See technical table G004
Communication interface	USB Atos ASCII coding
Communication physical layer	not insulated USB 2.0 + USB OTG

Size	16	25	32	40	50	63	80	
Max regulated flow [l/min]								
Δp P-T	at Δp = 5 bar	250	500	800	1200	2000	3000	4500
	at Δp = 10 bar	350	700	1100	1700	2800	4250	6350
Max permissible flow	600	1200	1800	2500	4000	6000	10000	
Max pressure [bar]	LIQZO		Ports A, B = 350		X = 350	Y ≤ 10		
	LIQZP		Ports A, B = 420		X = 350	Y ≤ 10		
Nominal flow of pilot valve at Δp = 70 bar [l/min]	43	43	43	50	50	50	50	
Leakage of pilot valve at P = 100 bar [l/min]	0,5	0,5	0,5	0,6	0,6	0,6	0,6	
Piloting pressure [bar]	min: 40% of system pressure			max 350	recommended 140 ÷ 160			
Piloting volume [cm³]	1,6	2,2	7,0	9,4	17,7	32,5	39,5	
Piloting flow (1) [l/min]	4,0	4,5	12	16	21	26	27	
Response time 0 ÷ 100% step signal (2) [ms]	25	30	35	35	50	75	90	
Hysteresis [% of the max regulation]	≤ 0,1							
Repeatability [% of the max regulation]	± 0,1							
Thermal drift	zero point displacement < 1% at ΔT = 40°C							

Note: above performance data refer to valves coupled with Atos electronic drivers, see section 5.

(1) with step reference input 0÷100%

(2) see detailed diagrams in section 6.2

4 SEALS AND HYDRAULIC FLUID - for other fluids not included in above table, consult our technical office

Seals, recommended temperature fluid	NBR seals (standard) = -20°C ÷ +60°C, with HFC hydraulic fluids = -20°C ÷ +50°C FKM seals (/PE option) = -20°C ÷ +80°C		
Recommended viscosity	20 ÷ 100 mm ² /s - max allowed range 15 ÷ 380 mm ² /s		
Fluid contamination class	ISO 4406 class 20/18/15 NAS 1638 class 9, in line filters of 10 µm (β10 ≥75 recommended)		
Hydraulic fluid	Suitable seals type	Classification	Ref. Standard
Mineral oils	NBR, FKM	HL, HLP, HLPD, HVLP, HVLPD	DIN 51524
Flame resistant without water	FKM	HFDU, HFDR	ISO 12922
Flame resistant with water	NBR	HFC	

5 ELECTRONIC DRIVERS

Valve model	TEB
Drivers model	E-RI-TEB-N
Type	Digital
Format	Integral to valve
Data sheet	GS208

Note: for main and communication connector see sections **9**, **10**

6 DIAGRAMS (based on mineral oil ISO VG 46 at 50 °C)

6.1 Regulation diagrams (values measured at Δp 5 bar)

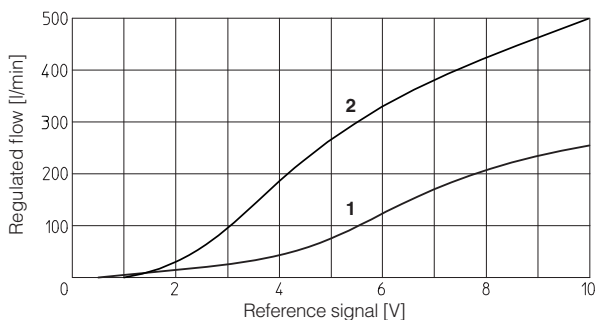

1 = LIQZO-TEB-16*
2 = LIQZO-TEB-25*

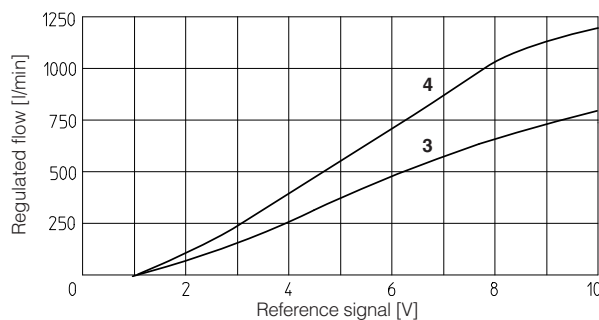

3 = LIQZO-TEB-32*
4 = LIQZO-TEB-40*

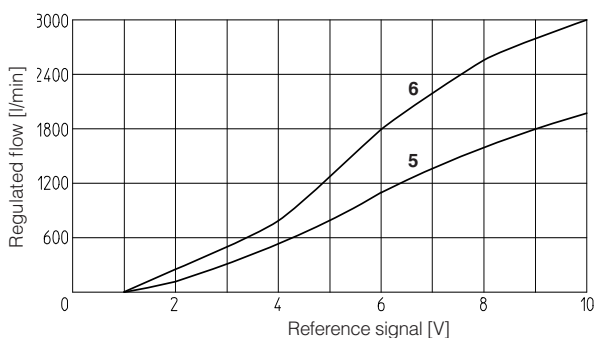

5 = LIQZP-TEB-50*
6 = LIQZP-TEB-63*

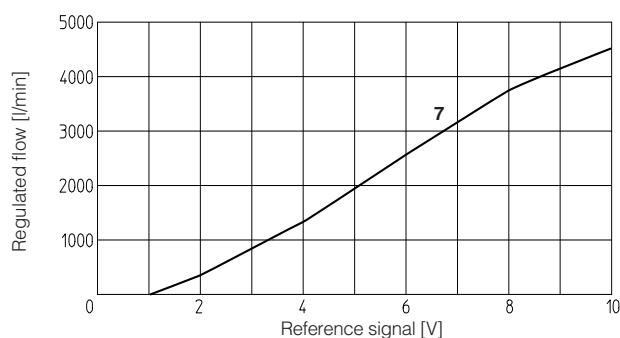

7 = LIQZP-TEB-80*

6.2 Response time

The response times in below diagrams are measured at different steps of the reference input signal. They have to be considered as average values. For the valves with digital electronics the dynamics performances can be optimized by setting the internal software parameters.

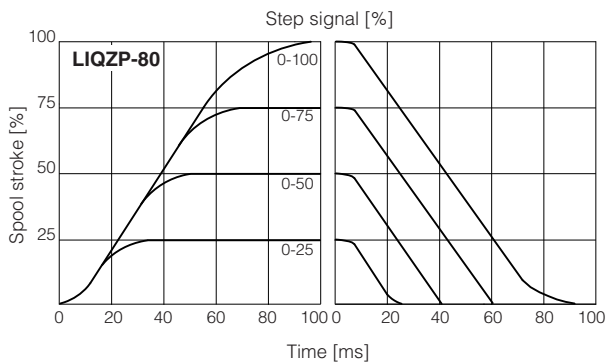
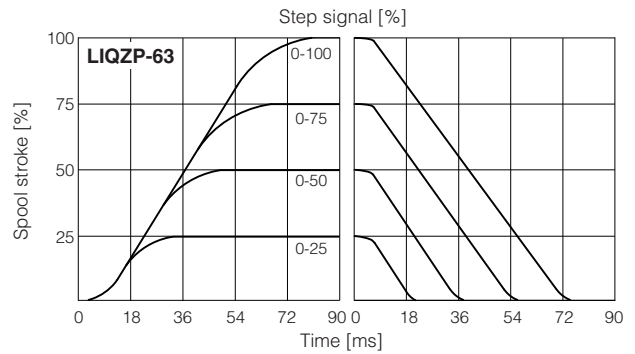
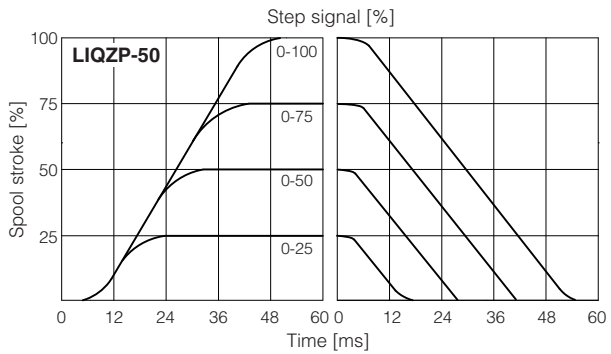
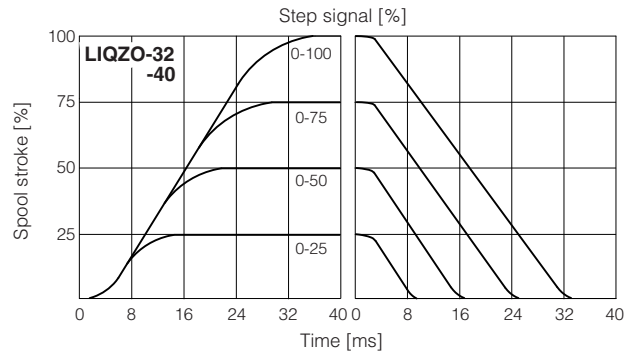
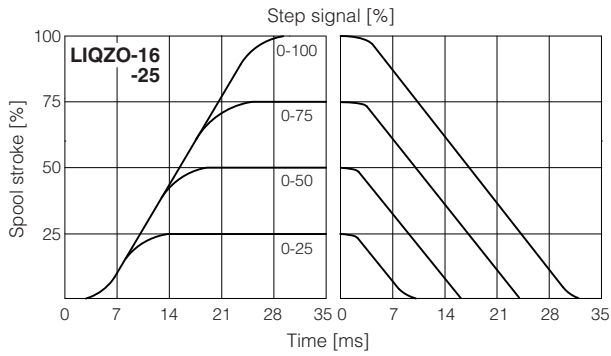

7 ADDITIONAL EXTERNAL PILOT PORT CONNECTION

Sizes 16 - 63

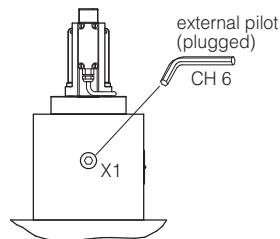
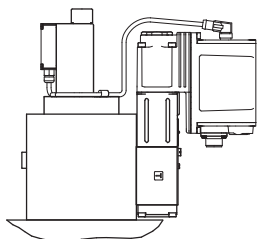

Size 80

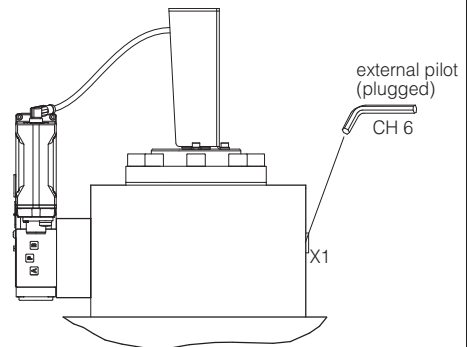

X1 = additional external pilot port connection G1/4"

8 ELECTRONIC OPTIONS

Standard driver execution provides on the 7 pin main connector:

Power supply - 24 VDC must be appropriately stabilized or rectified and filtered; a 2.5 A safety fuse is required in series to each driver power supply. Apply at least a 10000 μ F/40 V capacitance to single phase rectifiers or a 4700 μ F/40 V capacitance to three phase rectifiers.

Reference input signal - analog differential input with ± 10 VDC nominal range (pin D, E), proportional to desired valve spool position.

Monitor output signal - analog output signal proportional to the actual valve's spool position with ± 10 VDC nominal range.

A minimum time of 300 to 500 ms must be considered between the driver energizing with the 24 Vdc power supply and when the valve is ready to operate. During this time the current to the valve coils is switched to zero.

8.1 Option /F

It provides a Fault output signal in place of the Monitor output signal, to indicate fault conditions of the driver (cable interruption of spool transducers or reference signal - for /I option): Fault presence corresponds to 0 VDC, normal working corresponds to 24 VDC.

8.2 Option /I

It provides 4 \div 20 mA current reference and monitor signals, instead of the standard ± 10 V.

Input signal can be reconfigured via software selecting between voltage and current, within a maximum range of ± 10 V or ± 20 mA.

It is normally used in case of long distance between the machine control unit and the valve or where the reference signal can be affected by electrical noise; the valve functioning is disabled in case of reference signal cable breakage.

8.3 Option /Q

It provides the possibility to enable or disable the valve functioning without cutting the power supply (the valve functioning is disabled but the driver current output stage is still active). To enable the driver supply a 24 VDC on the enable input signal.

8.4 Option /Z

It provides, on the 12 pin main connector, the following additional features:

Enable Input Signal

To enable the driver, supply 24 VDC on pin 3 referred to pin 2: when the Enable signal is set to zero the valve functioning is disabled (zero current to the solenoid) but the driver current output stage is still active.

Fault Output Signal

Fault output signal indicates fault conditions of the driver (solenoid short circuits/not connected, reference signal cable broken for 4 \div 20mA input, etc.). Fault presence corresponds to 0 VDC, normal working corresponds to 24 VDC (pin 11 referred to pin 2): Fault status is not affected by the Enable input signal.

8.5 Possible combined options: /FI, /IQ and /IZ

9 ELECTRONIC CONNECTIONS AND LEADS

9.1 Main connector signals - 7 pin - standard, /F and /Q options (A1)

PIN	Standard	/Q	/F	TECHNICAL SPECIFICATIONS	NOTES
A	V+			Power supply 24 Vdc	Input - power supply
B	V0			Power supply 0 Vdc	Gnd - power supply
C	AGND		AGND	Analog ground	Gnd - analog signal
		ENABLE		Enable (24 Vdc) or disable (0 Vdc) the valve, referred to V0	Input - on/off signal
D	Q_INPUT+			Flow reference input signal: ± 10 Vdc / ± 20 mA maximum range Defaults are ± 10 Vdc for standard and 4 \div 20 mA for /I option	Input - analog signal Software selectable
E	INPUT-			Negative reference input signal for Q_INPUT+	Input - analog signal
F	Q_MONITOR referred to:			Flow monitor output signal: ± 10 Vdc / ± 20 mA maximum range Defaults are ± 10 Vdc for standard and 4 \div 20 mA for /I option	Output - analog signal Software selectable
	AGND	V0	FAULT	Fault (0 Vdc) or normal working (24 Vdc)	Output - on/off signal
G	EARTH			Internally connected to the driver housing	

9.2 Main connector signal - 12 pin - /Z option (A2)

PIN	TEB-SN /Z	TECHNICAL SPECIFICATIONS	NOTES
1	V+	Power supply 24 Vdc	Input - power supply
2	V0	Power supply 0 Vdc	Gnd - power supply
3	ENABLE referred to: V0	Enable (24 Vdc) or disable (0 Vdc) the valve	Input - on/off signal
4	Q_INPUT+	Flow reference input signal: ± 10 Vdc / ± 20 mA maximum range Defaults are ± 10 Vdc for standard and 4 \div 20 mA for /I option	Input - analog signal Software selectable
5	INPUT-	Negative reference input signal for Q_INPUT+	Input - analog signal
6	Q_MONITOR referred to: AGND	Flow monitor output signal: ± 10 Vdc / ± 20 mA maximum range Defaults are ± 10 Vdc for standard and 4 \div 20 mA for /I option	Input - analog signal Software selectable
7	AGND	Analog ground	Output - analog signal
8	R_ENABLE	Repeat enable, output repeter signal of enable input, referred to V0	
9	NC	Do not connect	
10	NC	Do not connect	
11	FAULT referred to: V0	Fault (0 Vdc) or normal working (24 Vdc)	Output - on/off signal
PE	EARTH	Internally connected to the driver housing	

9.3 Communications connectors (B) - (C)

(B) USB connector - M12 - 5 pin always present		
PIN	SIGNAL	TECHNICAL SPECIFICATION (1)
1	+5V_USB	Supply for external USB Flash Drive
2	ID	USB Flash Drive identification
3	GND_USB	Signal zero data line
4	D-	Data line -
5	D+	Data line +

Note (1): Shield connection on connector's housing is recommended.

9.4 Connections layout

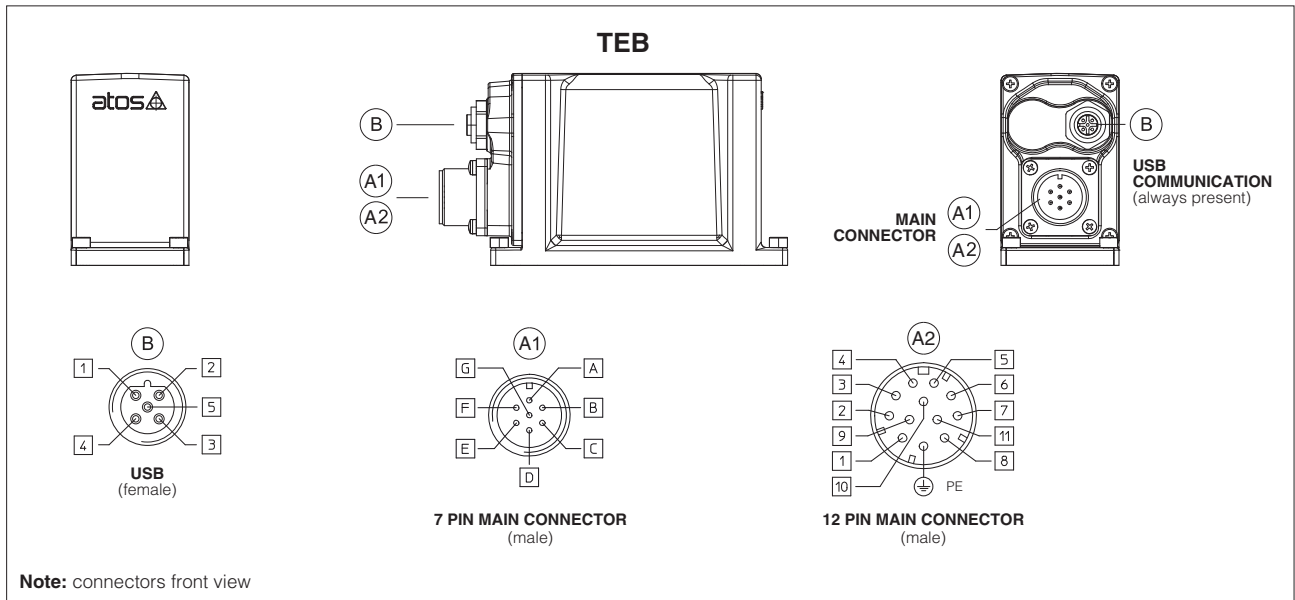

10 CONNECTORS

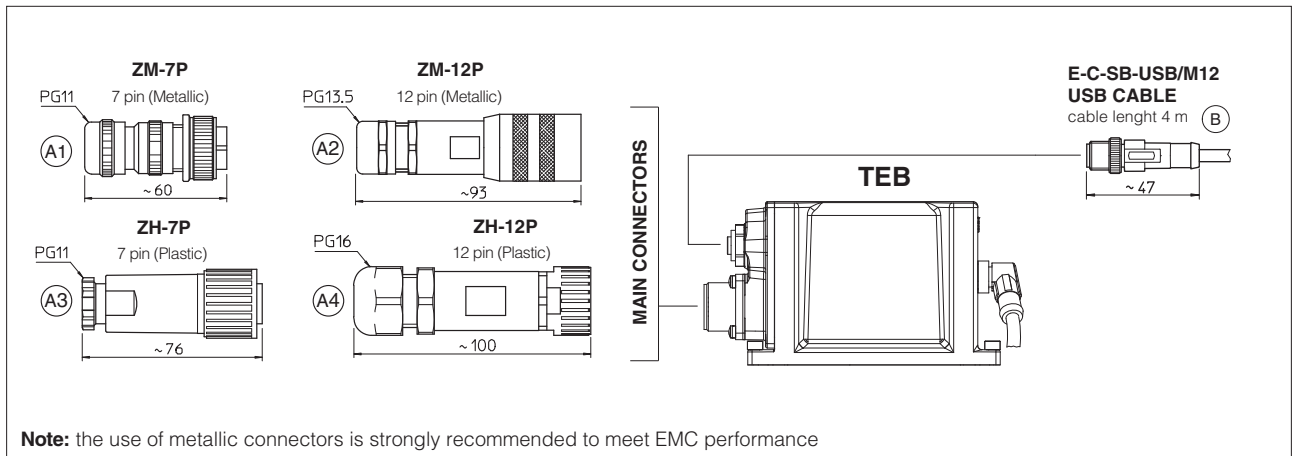

11 MODEL CODES OF MAIN CONNECTORS AND COMMUNICATION CONNECTORS - to be ordered separately

VALVE VERSION	TEB	TEB /Z
CONNECTOR CODE	ZM-7P (A1)	ZM-12P (A2)
	ZH-7P (A3)	ZH-12P (A4)
PROTECTION DEGREE	IP67	
DATA SHEET	GS208, K500	

12 PROGRAMMING TOOLS - see table GS500



Valve's functional parameters and configurations, can be easily set and optimized using Atos E-SW programming software connected via USB communication port to the digital driver. E-SW software is available in different versions according to the driver's fieldbus interface: NP (not present).

For fieldbus versions, E-SW software permits valve's parameterization through USB communication port also if the driver is connected to the central machine unit via fieldbus.

WARNING: drivers USB port is not isolated!

Use of E-A-SB-USB/OPT isolator adapter is highly recommended for PC protection.

USB connection

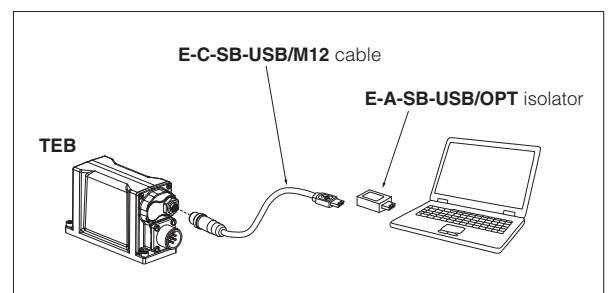

LIQZO fastening bolts and valve mass			
Size	Fastening bolts class 12.9	Tightening torque	Mass (Kg)
16	N°4 M8x90	35 Nm	6,2
25	N°4 M12x100	125 Nm	8,8
32	N°4 M16x60	300 Nm	11,2
40	N°4 M20x70	600 Nm	17,3

LIQZO-TEB-162

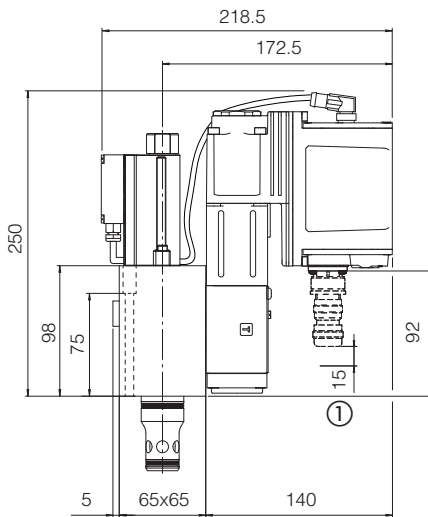

LIQZO-TEB-252

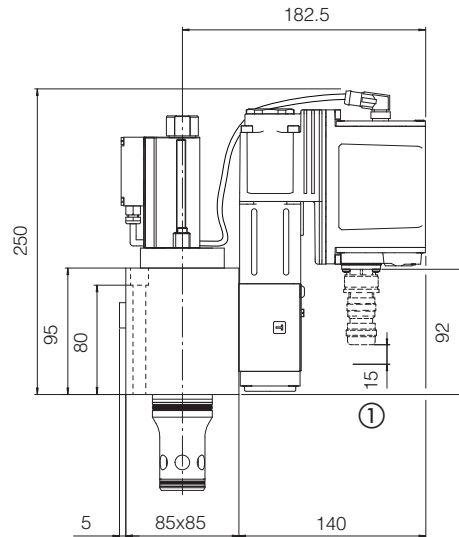

LIQZO-TEB-322

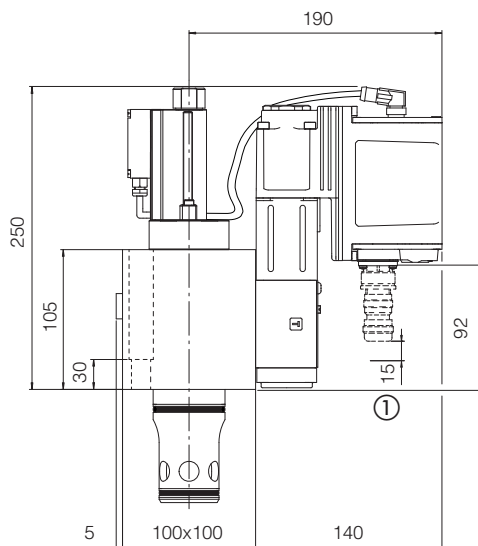

LIQZO-TEB-402

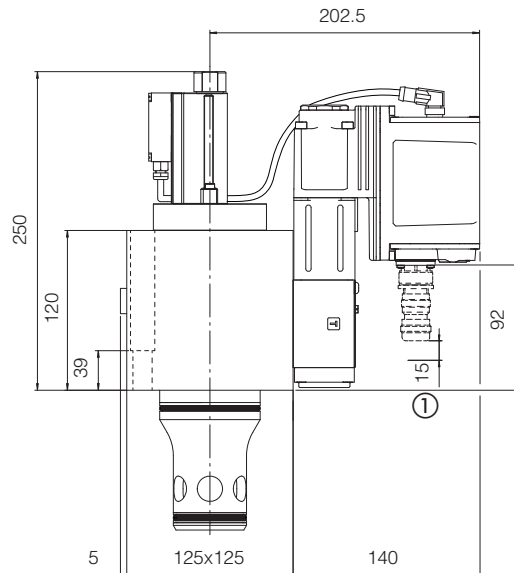

① Space to remove the 7 or 12 pin main connector. For main and communication connectors see section 9, 10

Note: for mounting surface and cavity dimensions, see table P006

LIQZP fastening bolts and valve mass			
Size	Fastening bolts class 12.9	Tightening torque	Mass (Kg)
50	N°4 M20x80	600 Nm	24,6
63	N°4 M30x120	2100 Nm	44,6
80	N°8 M24x80	1000 Nm	72,2

LIQZP-TEB-502

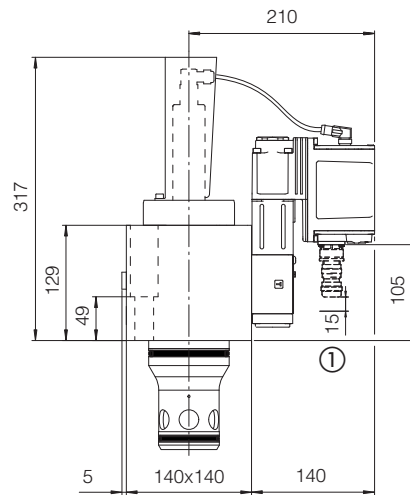

104119 LIQZP-TEB-632

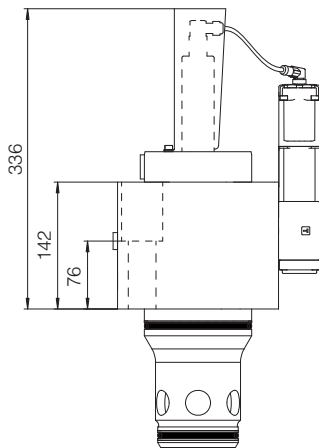

131114 LIQZP-TEB-802

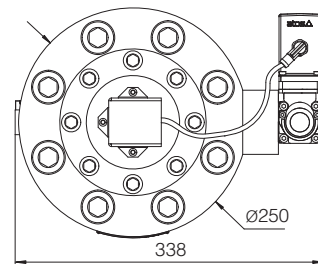
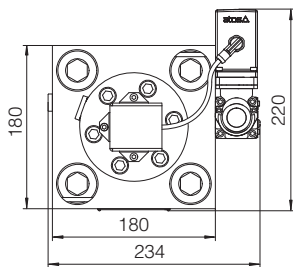
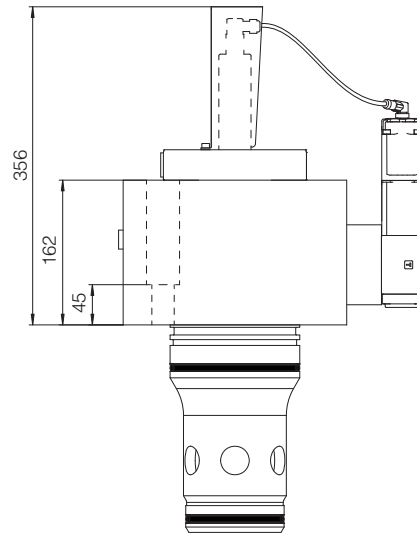

① Space to remove the 7 or 12 pin main connector. For main and communication connectors see section 9, 10

Note: for mounting surface and cavity dimensions, see table P006